

REGULATED DC POWER SUPPLY

PAD35-300LPT

PAD60-200LPT

INSTRUCTION MANUAL



Copyright © 1999 Kikusui Electronics Corporation.

All or any parts of this manual may not be reproduced in any forms, without express written permission of Kikusui Electronics Corporation.

The contents of this manual, including the specifications of the instrument, are subject to change without notice.

Printed in Japan. Z1-717-720 IB002181

Power Requirements of this Product

Power requirements of this product have been changed and the relevant sections of the Operation Manual should be revised accordingly.

(Revision should be applied to items indicated by a check mark)

Input voltage

The input voltage of this product is _____ VAC,
and the voltage range is _____ to _____ VAC. Use the product within this range only.

Input fuse

The rating of this product's input fuse is _____ A, _____ VAC, and _____.

WARNING

- To avoid electrical shock, always disconnect the AC power cable or turn off the switch on the switchboard before attempting to check or replace the fuse.
- Use a fuse element having a shape, rating, and characteristics suitable for this product. The use of a fuse with a different rating or one that short circuits the fuse holder may result in fire, electric shock, or irreparable damage.

AC power cable

The product is provided with AC power cables described below. If the cable has no power plug, attach a power plug or crimp-style terminals to the cable in accordance with the wire colors specified in the drawing.

WARNING

- The attachment of a power plug or crimp-style terminals must be carried out by qualified personnel.

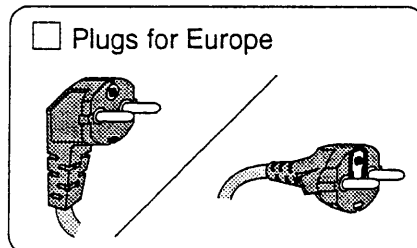
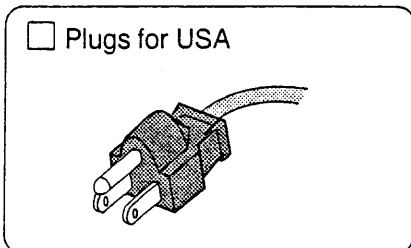
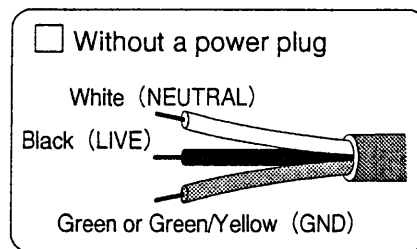
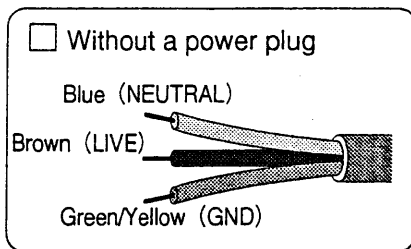

Provided by Kikusui agents
Kikusui agents can provide you with suitable AC power cable.
For further information, contact your Kikusui agent.

Another Cable _____

TABLE OF CONTENTS

	<u>PAGE</u>
SECTION 1. GENERAL	1
1-1. Description	1
1-2. Specifications	3
* Power Consumption Chart	6
* Mechanical Outline Drawing	8
SECTION 2. OPERATION	10
2-1. Precaution for Operation (Installation)	10
* Front and Rear Panel	16
2-2. Explanation of Front and Rear	18
2-3. Constant-Voltage Operation	24
2-4. Constant-current Operation	25
SECTION 3. PROTECTORS	26
3-1. Description	26
3-2. Explanation of Protective Circuits	27
3-3. Operation Method of Overvoltage Protector (OVP)	29
SECTION 4. APPLICATIONS	30
4-1. Remote Sensing	30
4-2. Output Voltage Control with an External Voltage or Resistanec	31
4-3. On-off Control of Output	36
4-4. Output Current Control with an External Voltage or Resistance	38
4-5. One-control Parallel Operation	41
4-6. One-control Series Operation	45
4-7. Constant-current Charge/Discharge of Battery or Capacitor ..	48
4-8. Remote Turning Off of The Power Switch	50
4-9. Contact Signals	51

	PAGE
SECTION 5. THEORY OF OPERATION	52
5-1. Description of Pre-regulation Circuit	52
5-2. Controlled Rectifier Circuit Filter and Circuit	54
5-3. Phase Control Circuit	55
5-4. Constant-voltage Circuit	56
5-5. Constant-current Circuit	58
5-6. Differences from Ideal Power Supply	60
* Block Diagram	63
 SECTION 6. MAINTENANCE	 64
6-1. Inspection and Adjustment	64
6-2. Troubleshooting	69

SECTION 1. GENERAL

1-1. Description

The PAD-L Power supply is designed for high operation reliability and excellent electrical performance. It is a universal-purpose industrial power supply which can be used as a variable power source for research and development, or as a fixed power source for long time aging test. Features of the PAD-L Power Supply can be summarized as follows:

1. Improved power factor at low output voltage:

A choke input system is used for the rectifier filter circuit, thereby reducing the apparent input current and improving the power factor. This led to a smaller power transformer and consequently to a compact and light power supply.

2. Less waveform distortion caused to the AC input line:

As the choke input system is used, the input current waveform is less distorted with harmonics, thereby reducing waveform distortion to the AC input line.

3. Excellent temperature coefficient:

Very low temperature drift characteristics of 50 ppm/°C is attained by using premium-quality parts, improved circuits, and forced air cooling. Time-elapse drift (aging drift) also is very low.

4. Fast transient response:

A wide-band error amplifier is used to ensure stable frequency-gain, phase characteristics.

5. Low ripple and noise voltages:

Ripple and noise voltages are low, both in rms and peak values.

The output voltage/current is finely adjustable from 0 V to the rated voltage/current with a 10-turn potentiometer.

The power supply has a current/voltage limit switch to preset a current/voltage value. The set value of constant-voltage/constant-current operation can be checked when in operation.

The power supply has internal protection such as voltage detector, current detector and temperature detector circuits. A high speed overvoltage protector (a thyristor crowbar protection circuit), voltage adjustable from the front panel, also is incorporated as a standard feature.

The power supply is housed in a casing for bench top use. It can be installed on a standard 19-inch (500-mm) rack.

The user is requested to read thoroughly this instruction manual before operating the power supply.

1-1 Specifications

		Models	
		PAD 35-300LPT	PAD 60-200LPT
Input			
AC input			
Power consumption 200V AC, rated load (typical)			
		3-phase 200V AC $\pm 10\%$, 50/60Hz	
		Approx. 18 kVA	Approx. 19 kVA
Output			
Output voltage range		0 to 35 V	0 to 60 V
Voltage resolution (Calculated value)		Approx. 7 mV	Approx. 11 mV
Output current range		0 to 300 A	0 to 200 A
Current resolution (Calculated value)		Approx. 90 mA	Approx. 60 mA
Constant-voltage characteristics			
Regulation			
Source effect (line regulation) (For $\pm 10\%$ change of line voltage)		*1 0.005% + 1 mV	
Load effect (load regulation) (For 0 to 100% change of output current)		0.005% + 2 mV	
Ripple and noise		500 μ V rms	
Transient response		100 μ sec	
Temperature coefficient (typical)		50 ppm/ $^{\circ}$ C	
Remote control Resistance		Approx. 0 to 10 k Ω	
Remote control Voltage		Approx. 0 to 10 V	
Constant-current characteristics			
Regulation			
Source effect (line regulation) (For $\pm 10\%$ change of line voltage)		*2 30 mA	
Load effect (load regulation) (For 0 to 100% change of output voltage)		30 mA	
Ripple and noise		200 mA rms	100 mA rms
Remote control Resistance		Approx. 0 to 500 Ω	
Remote control Voltage		Approx. 0 to 330 mV	

Models	
Operating ambient temperature range	PAD 35-300LPT PAD 60-200LPT 0 to 40°C (32 to 104°F)
Operating ambient humidity range	10 to 90% RH
Cooling method	Forced air cooling with fan
Polarity of output voltage	Positive or negative grounded
Isolation from ground	±250 V DC
Protections	
Overvoltage protection	
Voltage setting range	3 to 38 V 3 to 66 V
Trigger Pulse width	200 µsec
Operation	
OVP thyristor switch	
ON	
OFF	
Overcurrent protection	Output shorted with thyristor and cuts out input switch Input power switch is turned off.
Rush current suppression circuit	Trip at 110% of rated output current
Overtemperature protection (Cuts out input switch)	Input current 300 A peak or less 100±5°C (212±9°F) 130°C (266°F) at power transformer
Input fuse rating	60 A 70 A
Output fuse rating	300 A 200 A
Thermal fuse rating	Blows out at 135°C (275°F)
Output signals	Rear panel, 6 pins, DIN type
Constant-voltage operation indication	Contact made when in C.V mode
Constant-current operation indication	Contact made when in C.C mode
Power ON-OFF indication	Made and broken
Input signal	Input power switch is turned off by a make-contact signal.
Meters	
Voltmeter	Full scale JIS class 1.5 40 V DC 66 V DC
Ammeter	Full scale JIS class 1.5 300 A DC 200 A DC
Constant-voltage mode indication	C.V : With green LED
Constant-current mode indication	C.C : With red LED

Insulation resistance		Models	
Between chassis and input	PAD 35-300LPT	PAD 60-200LPT	
Between chassis and output	500V DC 30M Ω or more	500V DC 20M Ω or more	
Dimensions			
Maximum dimensions	430 W \times 840 H \times 600 D mm (16.93 W \times 33.07 H \times 23.62 D in.)		
Rack mounting	440 W \times 942 H \times 750 D mm (17.32 W \times 37.09 H \times 29.53 D in.)		
Bracket for EIA rack (19 in.)	BH19		
Bracket for JIS rack (mm-unit rack)	BH17M		
Weight	Approx. 220 kg (485 lbs)	Approx. 210 kg (463 lbs)	
Accessories (in carton)			
Instruction manual	1 copy		
Input cord	4-core cabtire cord, approx. 4 m (13 ft.), normal core cross section 14 mm ²		
Voltage check chips	2 ea.		
Input line fuses (spare 3 ea.)	60 A (200V AC)	70 A (200V AC)	
Guard cap	1 set		
Lamp (OL-394)	2 ea. (12 V, 40 mA)		
DIN connector (6 pins)	1 ea.		

- NOTES
- *1 Measured using the sensing terminals.
 - *2 Measured with the positive or negative output terminal grounded.
 - *3 Load effect recovery time within 0.05%+10mV of the setting output voltage.
(for 10 to 100% change of output current)
 - *4 Pulse width for trip
 - *5 With rack mount brackets (option), can be mounted on a standard 19-inch or 500-mm rack.

Power Consumption Chart

PAD 35 - 300LPT

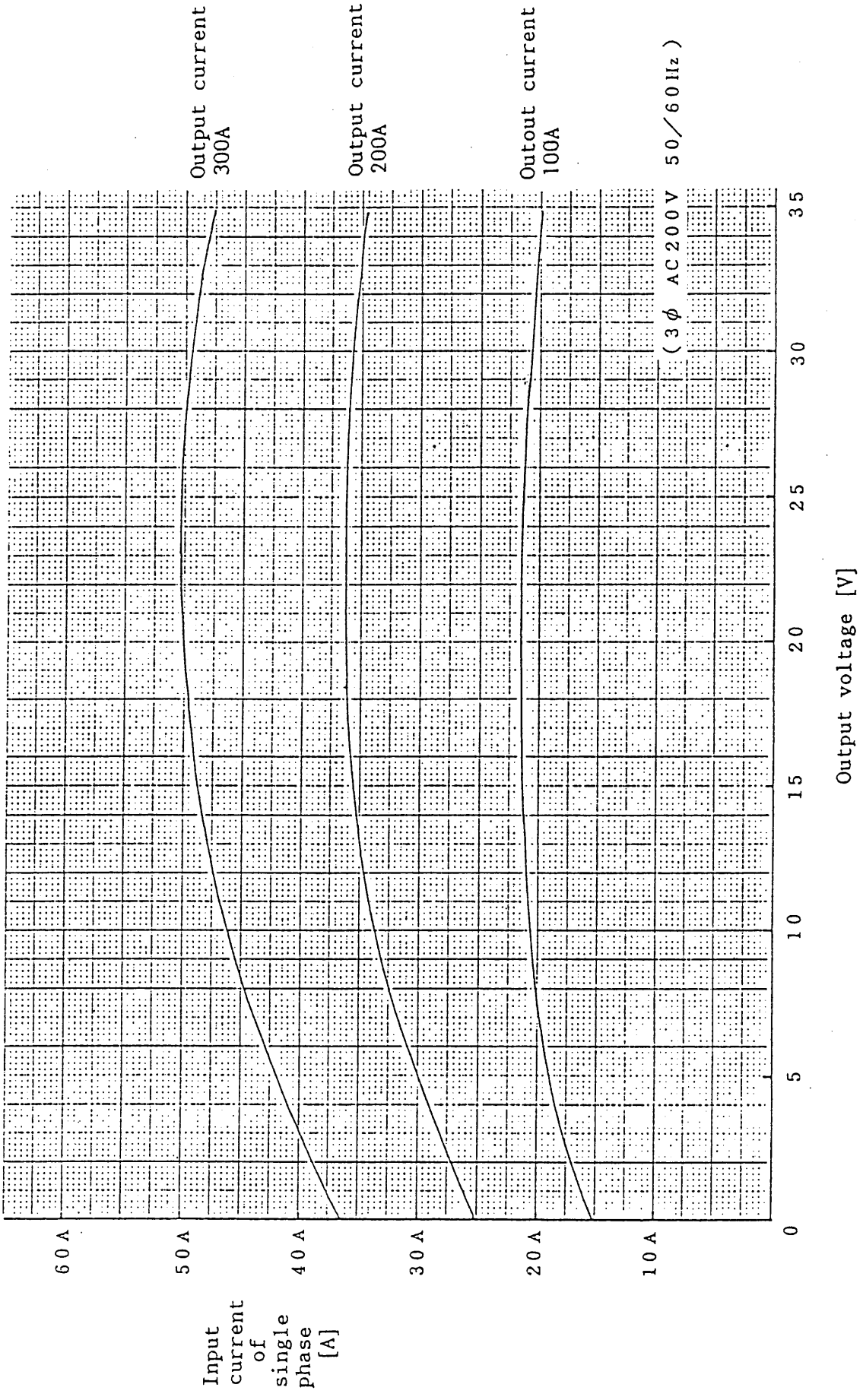

Power Consumption Chart

PAD60 - 200LPT

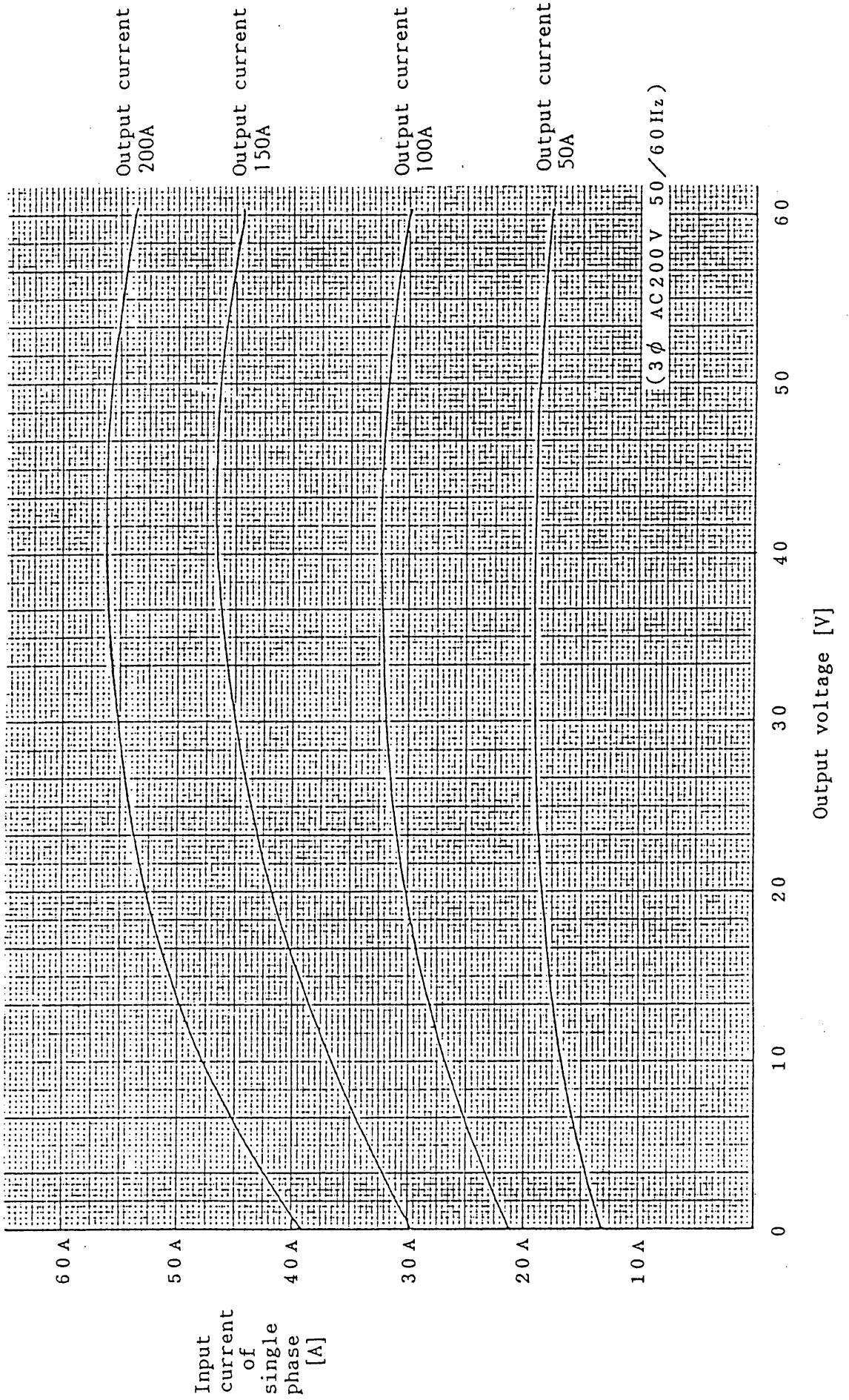

(Note) Brackets for rack mount
are option.

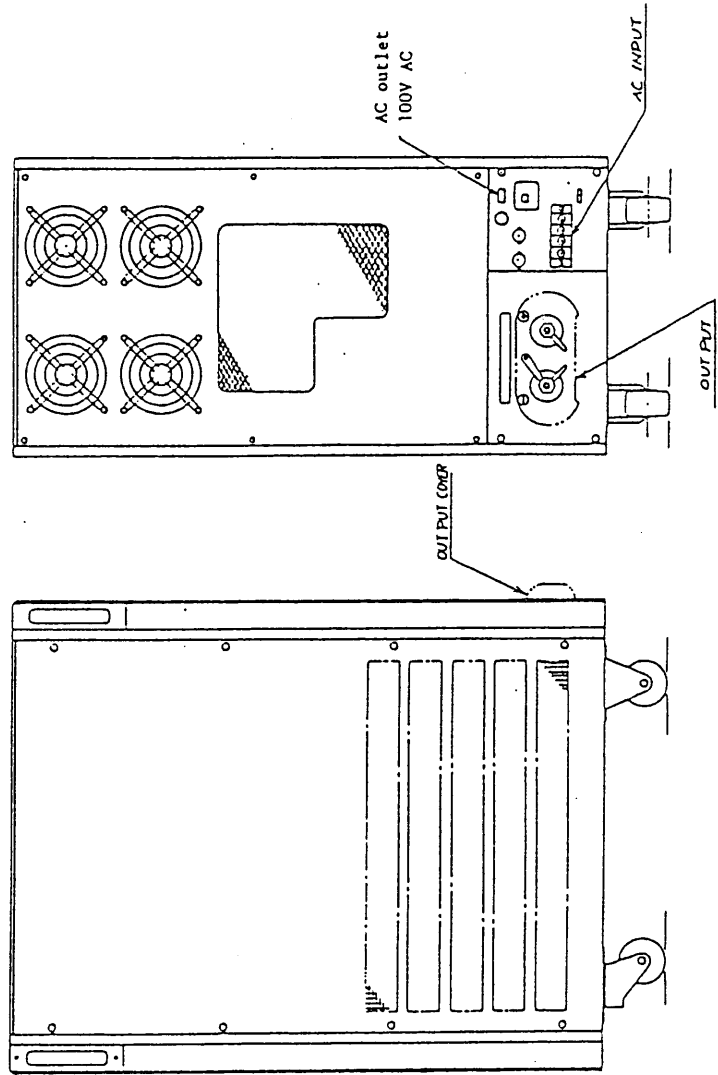
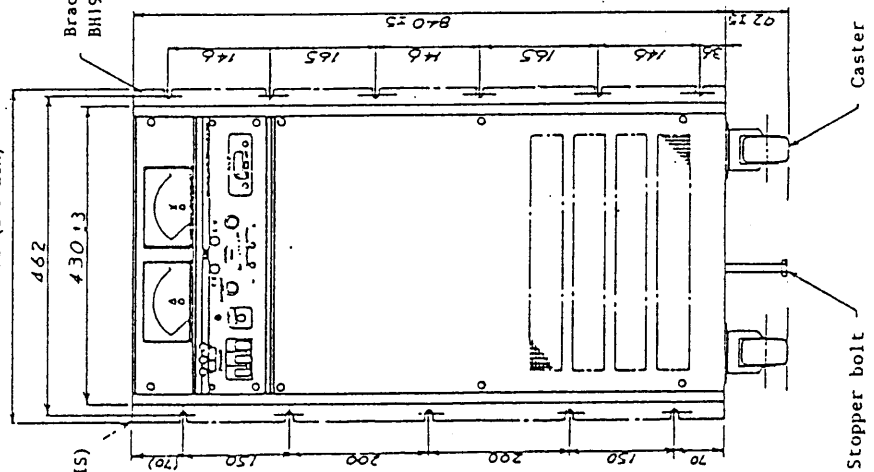
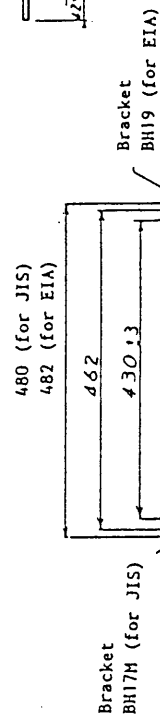
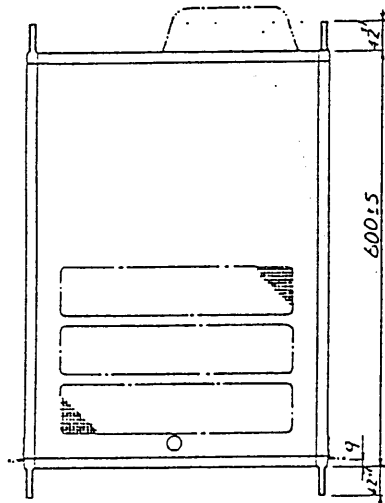

Mechanical Outline Drawing (PAD60-200LPT)

SECTION 2. OPERATION

2-1. Precaution for Operation (Installation)

1. Input power

- The input voltage range is 180 to 220 V, 50 or 60 Hz 3-phase AC.
- The switch to select 50 or 60 Hz line frequency is located on the rear panel as shown in Figure 2-1.

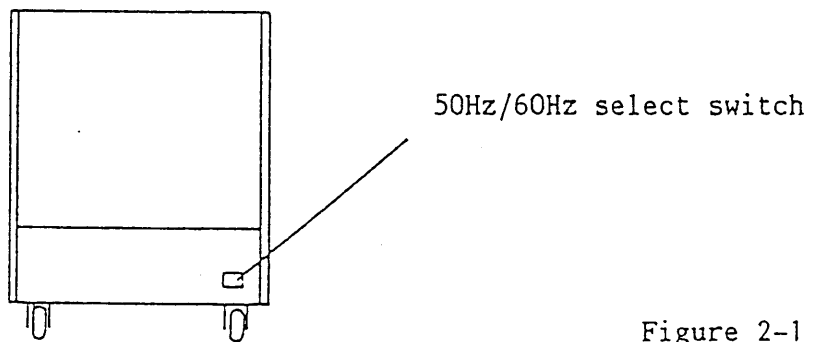

Figure 2-1

Selection is done as you turnover the frequency mark-plate:
The front plane for 50 Hz and the back plane for 60 Hz.

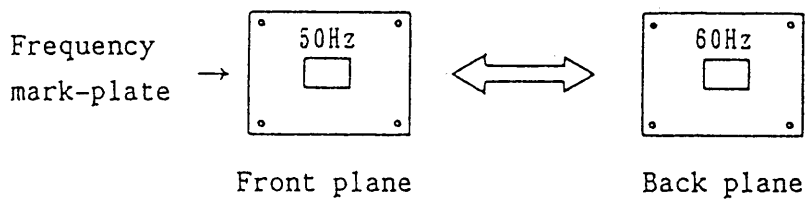
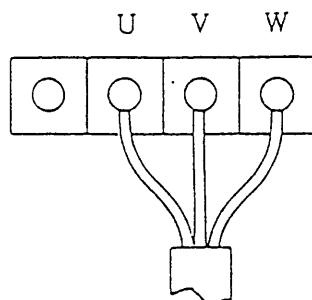

Figure 2-2

- The AC power input circuit of the power supply employs the "free phase rotation system" which accepts the 3-phase input power in any phases. This allows you to connect the input-power phase lines (U, V, W) to any of the AC power input terminals (U, V, W) taking no heed of their phases.



Free phase rotation system
(Any lines can be connected
to any terminals.)

Figure 2-3

- For current consumption, see the power consumption charts.

2. Power cord

- The input cord supplied accompanying this instrument is for 240 V AC. Its conductor wire cross section area is 14 mm².
- Use a cable of cross section area 14 mm² or over and its wire securely with crimping terminals.
- The green wire is for ground. Be sure to connect this wire to a good earth ground for safety.

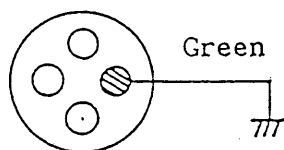

Figure 2-4. Cross section of cable

Table 2-1. Wire gauges and current ratings

Ta=30°C (86°F)

Nominal cross section	Maximum current recommended by Kikusui	Maximum current designated by Electrical Installation Technical Ordinance (Article 29) JAPAN
2 mm ²	10 A	27 A
5.5mm ²	20 A	49 A
8 mm ²	30 A	61 A
14 mm ²	50 A	88 A
22 mm ²	80 A	115 A
30 mm ²		139 A
38 mm ²	100 A	162 A
50 mm ²		190 A
60 mm ²		217 A
80 mm ²	200 A	257 A
100 mm ²		298 A
125 mm ²		344 A
150 mm ²	300 A	395 A
200 mm ²		469 A

3. PRECAUTIONS

The "LP" Power supplies has an internal crowbar circuit. Therefore, they must not be used for charging of batteries or large capacitors, must not be operated in parallel with same Model or the other power supply. Note that damage may be caused as the load is shorted when the OVP has tripped. To guard against such damage when such use is unavoidable, connect a diode (D1 in the illustration) in series to the load.

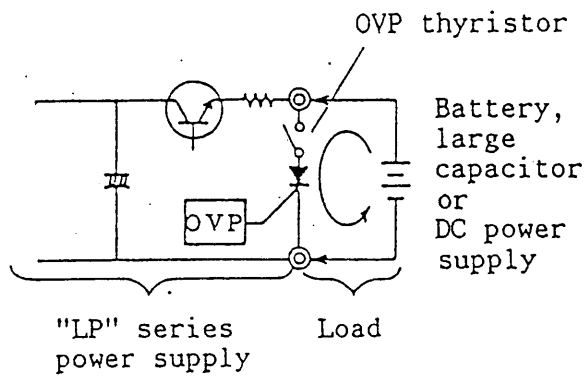

Figure 2-5

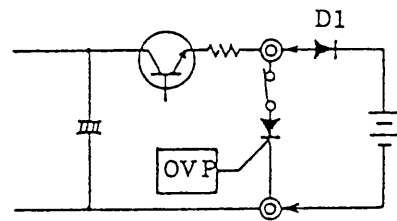

Figure 2-6

4. Output

- o Make sure that the jumpers of the terminal blocks on the rear panel are securely connected as shown in Figure 2-2.

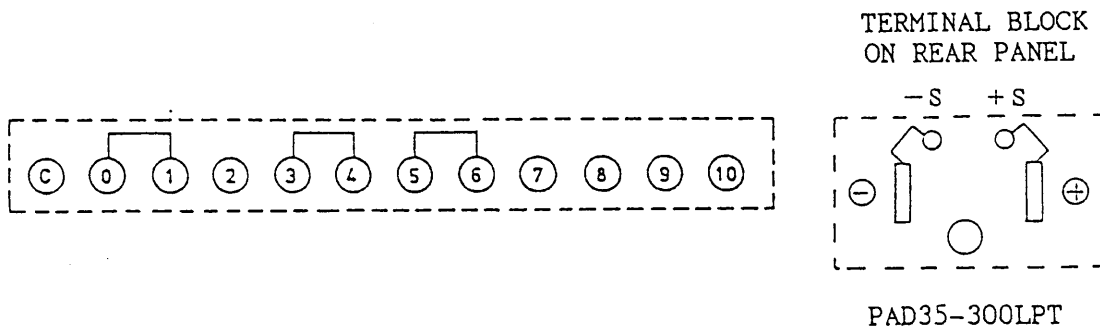
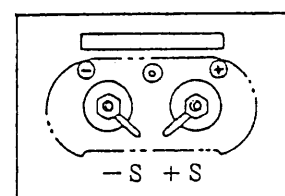

Figure 2-7



- Normally, connect either one of the output terminals to the GND terminal with the shorting bar.
- For connecting the output to a load, use wires of a sufficient current rating referring to Table 2-1. If wires of an insufficient current rating is used, the voltage at the load may become unstable due to voltage drop in the wires, or the wires may be overheated in an extreme case.

5. Ambient temperature

- The ambient temperature range for the power supply to satisfy the specification performances is 0°C to 40°C (32°F to 104°F). The power supply should be used within this range. If it is operated at a high ambient temperature, the internal temperature detector circuit trips and the input power switch is turned off. If this has happened, cool it and then turn on the power again. There is an exponential relationship between ambient temperature and semiconductor life, electrolytic capacitor life and transformer insulation life. Note that components are rapidly deteriorated at high temperatures. It is important not to operate the power supply at an abnormally high ambient temperature also from the viewpoint of its life.
- If the power supply is used at a temperature lower than -10°C (14°F), its operation may become unstable. If the power supply is to be used at low temperatures, specify so when ordering.

6. Place for use

- Pay attention so that the ventilation ports (top and bottom) and the fan air outlet are not blocked.
- Hot air comes out of the fan air outlet. Do not place near the outlet an object which is not heat resistant.
- Do not use the power supply in a highly humid or dusty place as such can cause failures.

- o Select a place where is reasonably free from vibration.
- o Do not place a high sensitivity instrument on or near the power supply which produces a strong electric and magnetic fields.

7. Note for carrying

- o The power supply weights more than 200 kg (440 lbs) and its center of gravity is located at a forward position.

Be extremely careful when moving the power supply.

8. Note for load

Note that the output may become unstable depending on characteristics of loads as follows:

- (a) When the meter reading (average value) is less than the preset value, if the current has peaks which exceed the preset value, the operation is driven into the constant current domain for the short periods of time and the output voltage falls. Observing carefully, it can be seen that the constant-current indicator lamp becomes dim.

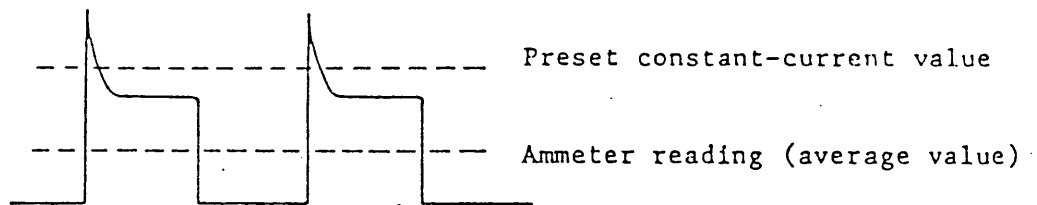

Figure 2-8. Load current with peaks

In this case, raise the preset value or increase the current rating.

- (b) When a regenerative load (such as inverter, converter, or transformer) is connected to the power supply, as it cannot absorb the reverse current fed from the load, the output voltage increases and becomes unstable. In such a case, connect a bypass resistor (R) in parallel with the load and feed in this resistor a current larger than the maximum reverse current.

$$R [\Omega] \cong \frac{E_o [V]}{I_{RP} [A]}$$

where, E_o : Output Voltage

I_{RP} : Maximum reverse current

9. Fixed or Semi-fixed Output

When a guard cap (accessory) used, the potentiometer is fixed or semi-fixed as shown under.

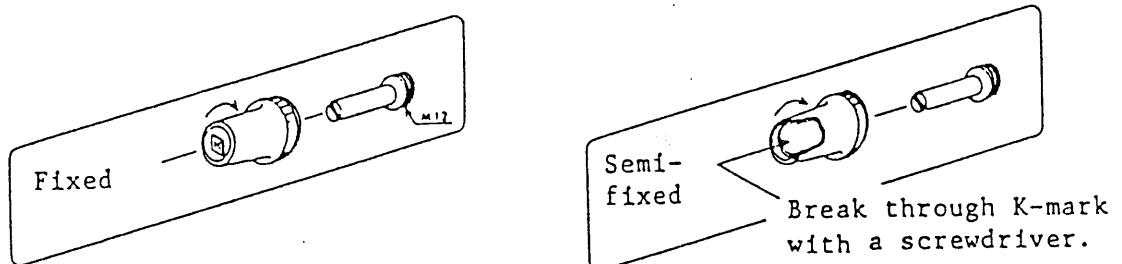
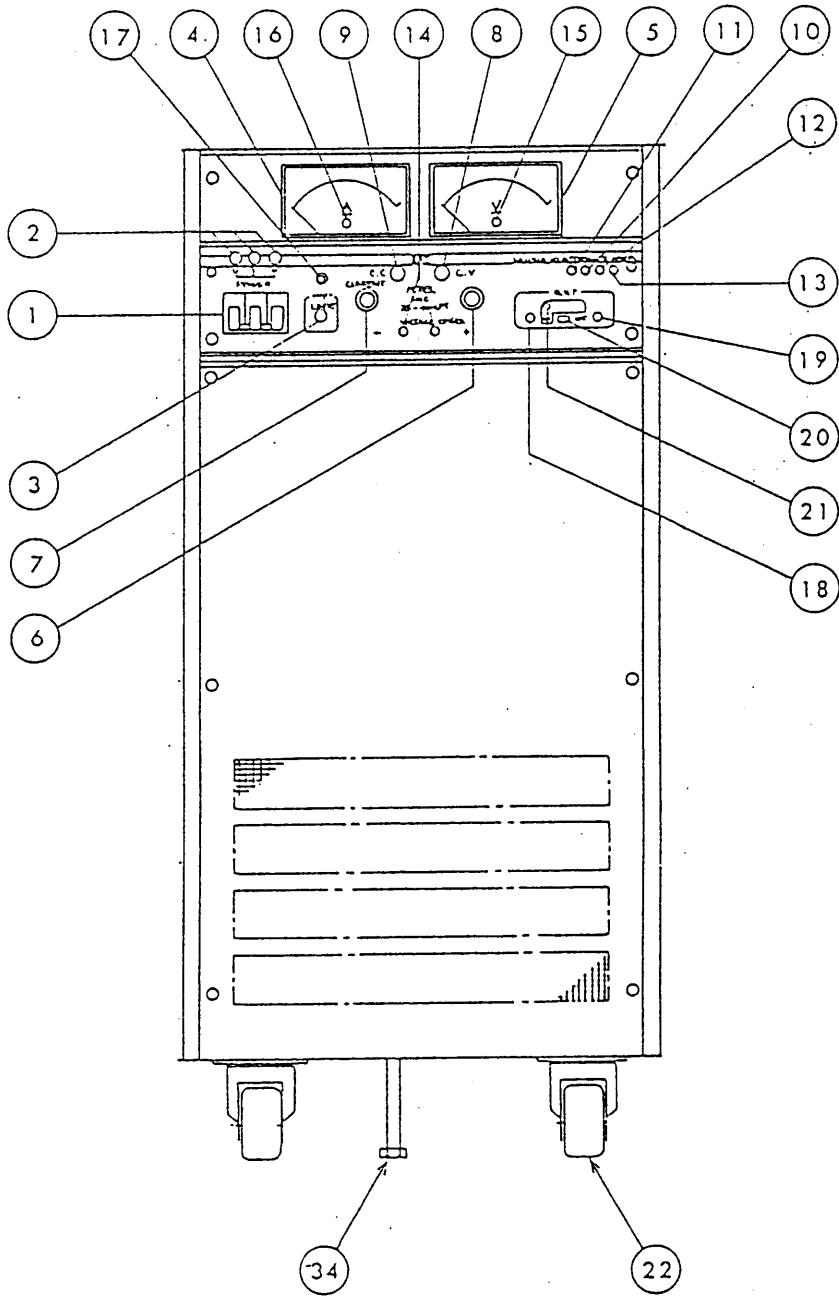
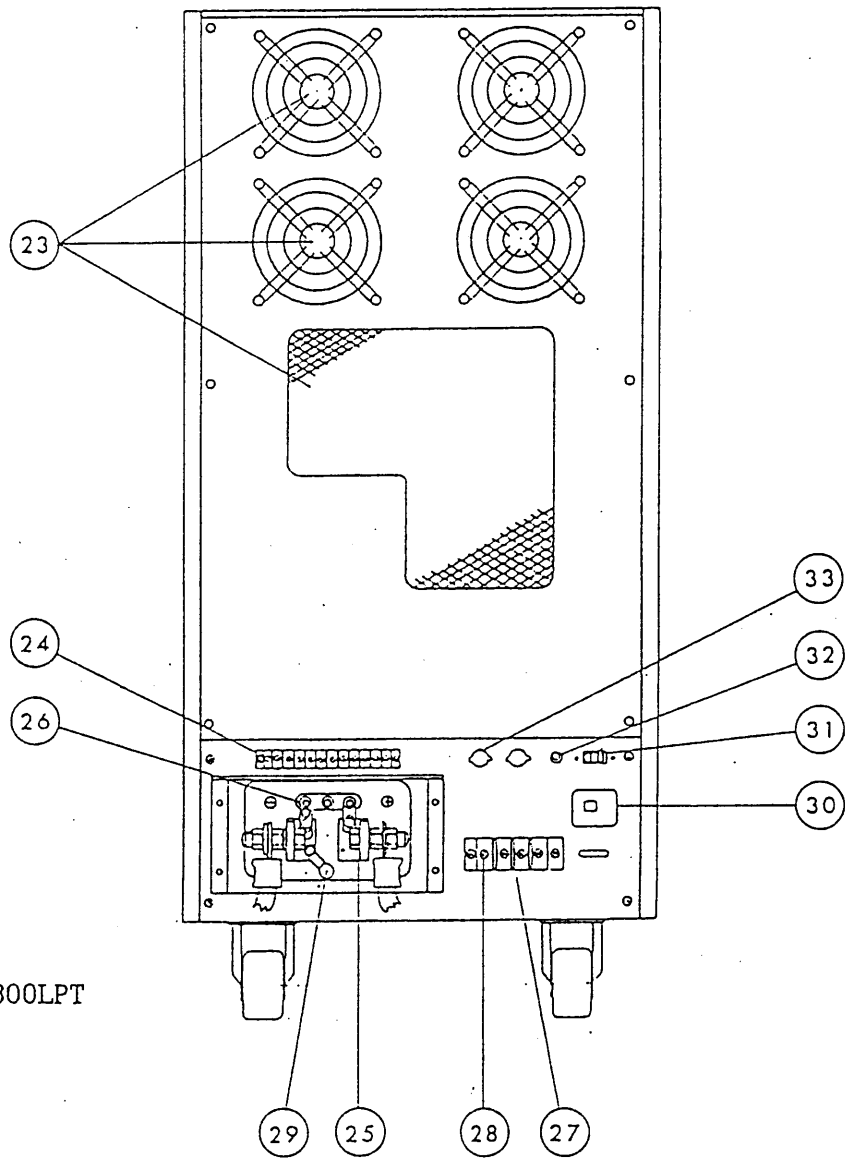

Figure 2-9



PAD35-300LPT
 PAD60-200LPT

Figure 2-10. Front Panel



PAD35-300LPT

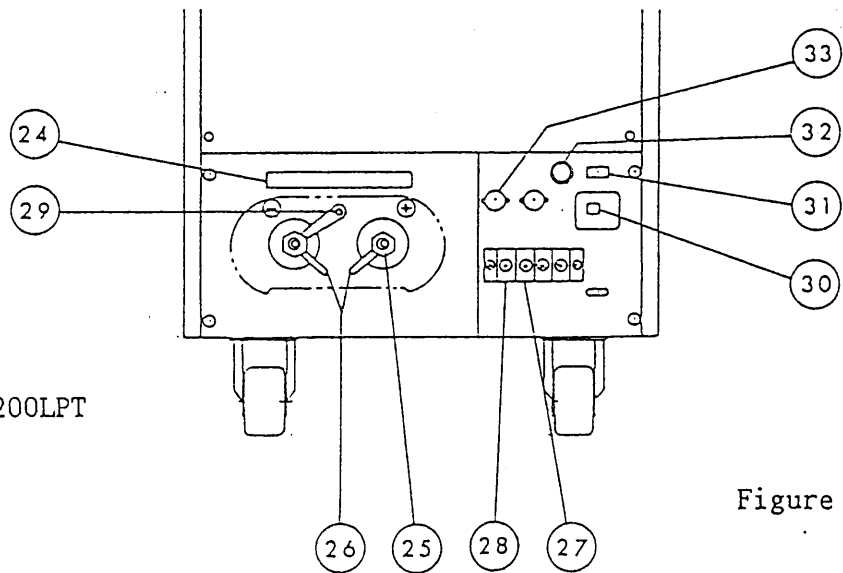

PAD60-200LPT

Figure 2-11. Rear Panel

2-2. Explanation of Front and Rear

Panel items and descriptions

1. POWER switch

Serves as AC power switch. When this switch is thrown to the upper position, the instrument power is turned on and the power indicator lamp lights.

Note: When any one of the internal protectors (overvoltage protector, voltage detector, current detector, and temperature detector) has tripped, this switch is automatically turned off. Once it has been turned off, it cannot be immediately turned on. Wait about 60 minutes before turning on the switch again. Be sure to eliminate the cause of switch trip before turning on the switch again.

2. POWER indicator lamp:

- o When in the normal operation, all of the POWER indicator lamps illuminates as the POWER switch is turned on.
- o When one of the phase lines of the input power has failed or its fuse is blown out, the POWER indicator lamp of the corresponding phase does not illuminate to indicate the abnormality.
(See Figure 6-1.) PAD35-300LPT 60 A
 PAD60-200LPT 70 A

3. CURRENT/VOLTAGE LIMIT switch:

Push to set crossover point of C.V/C.C. The ammeter indicates the preset constant-current value and the voltmeter indicates the preset constant-voltage value.

4. Ammeter:

Monitors output current. Accuracy $\pm 1.5\%$ of full scale

5. Voltmeter:

Monitors output voltage. Accuracy $\pm 1.5\%$ of full scale

6. Voltage setting knob:

Adjusts output voltage for constant-voltage operation.

10-turn potentiometer

(See Fixed or semi-fixed output page 15.)

7. Current setting knob:

Adjusts current for constant-current operation.

10-turn potentiometer

(See Fixed or semi-fixed output page 15.)

8. C.V (constant-voltage operation indicator lamp):

Energizes in constant-voltage mode.

Color: Green.

Type : OL-394 (12 V, 40 mA).

9. C.C (constant-current operation indicator lamp):

Energizes in constant-current mode.

Color: Red.

Type : OL-394 (12 V, 40 mA).

10. Voltmeter calibration:

For voltmeter calibration. (Periodically calibrate the voltmeter referring to SECTION 6 "MAINTENANCE.")

11. Ammeter calibration:

For ammeter calibration. (Periodically calibrate the ammeter referring to SECTION 6 "MAINTENANCE.")

12. Output current offset control (I.os)

For adjustment of output current when the current setting knob is turned to the counterclockwise extreme position or for adjustment of input offset voltage when in remote control with voltage signal.

13. Output voltage offset control (V.os)

For adjustment of output voltage when the voltage setting knob is turned to the counterclockwise extreme position or for adjustment of input offset voltage when in remote control with voltage signal.

14. VOLTAGE CHECK*

For checking the output voltage from the front panel. Can be set at the output voltage using the chips supplied.
Fuse (0.1 A) is incorporated.

15. Zero adjustment of voltmeter:

To adjust the voltmeter at 0 V.

16. Zero adjustment of ammeter:

To adjust the ammeter at 0 A.

17. ALARM lamp:

When one of the below-mentioned protective circuits has tripped, the POWER switch is turned off and the ALARM lamp illuminates. The lamp is reset as the cause of the protector trip is eliminated and the POWER switch is turned on.

- o High-speed overvoltage protector
- o Voltage detection circuit
- o Temperature detection circuit
- o Overcurrent detection circuit

For the functions of the protective circuit, refer to SECTION 3 "PROTECTORS."

18. Overvoltage protector (OVP) (See 3-3 "Operation Method of Over-voltage Protector."):

When the output voltage has exceeded the set value due to inadvertent operation or instrument failure, the input power switch is instantaneously cut off to protect the load.

19. PRESET OVP switch:

Push to check OVP trip voltage. The voltmeter indicates the OVP trip voltage.

OVP setting procedure

1. Keeping the PRESET OVP switch depressed, set the voltage using a plain screwdriver.
 2. Check that the OVP circuit trips by raising the output voltage.
 - o Even when the power supply is in use, voltage setting can be confirmed.
20. OVP thyristor switch (CROWBAR mode select switch):

This switch selects the CROWBAR mode such that, when the over-voltage protector has tripped, the thyristor connected in parallel to the output terminals is turned on to draw a current to protect the load. The switch should be turned on when the load is a semiconductor or other device which is not resistant against overvoltage; it should be turned off when the load is a battery or other device which feeds power.

21. CROWBAR lamp:

This lamp (LED) illuminates to indicate that the CROWBAR mode is selected. (Refer to Section 3-3.)

22. Casters:

For moving the instrument

23. Fan exhaust area:

Air exit of the cooling package. As hot air comes out of this outlet, do not obstruct. The outlet must be positioned 30 cm or over from wall.

24. Terminal block:

Terminals for remote control and series/parallel operation of two or more units. (See SECTION 4 "APPLICATIONS.")

25. Output terminals:

Provide the output power. Terminal section M12.

26. Sensing terminal (sampling terminals):

These terminals are used for remote sensing.
(See SECTION 4 "APPLICATIONS.")

- o When operated in the constant-voltage mode, this terminal provides the signal for regulating the output.
- o When operated in the remote sensing mode, disconnect the jumper from between output terminal and sensing terminal, and connect the sensing signal wires to the load point where the voltage is to be regulated.
(Refer to the section for applications.)
- o Do not connect any load to the sensing terminal.

27. Input terminals board:

For input power connection. For 200 V 3-phase AC power, use the power cord supplied accompanying the instrument. (cross section area 14 mm² or over)

28. GND terminal:

Be sure to connect this terminal to a good earth ground.

29. Ground shorting bar:

The bar is used to short the "+" or "-" output terminal to the GND terminal. Normally, either one of the output terminals should be connected to the GND terminal.

(Refer to Section 2-1.)

30. Line frequency select switch:

The switch selects AC line frequency 50 Hz or 60 Hz. Selection is done as you turnover the frequency mark-plate. (Refer to Section 2-1.)

31. AC outlet:

Provides AC power (100 V, 1 A).

32. Fuse holder:

Houses a fuse 1 ampere for AC outlet.

33. DIN terminals:

The terminals deliver a contact signal representing the constant-voltage mode, constant-current mode, or power on/off state. (See Section 4-9.)

34. Stopper bolts:

The bolts (two, M10) are used to fix the power supply. One bolt is located at the front and the other at the rear.

2-3. Constant-Voltage Operation

Check first that the AC line voltage is 200 V \pm 10% AC.

Then, proceed as follows:

- (1) Turn the current setting knob to the extremely counterclockwise position.
- (2) Turn on the input power switch. The C.C lamp (red) will light indicating that the instrument power is on.
- (3) Keeping depressed the current/voltage limit switch, set the output voltage at the required value with the voltage setting knob. By this procedure, setting of the output voltage is complete. (At this stage, the output power is not delivered to the output terminals yet.)
- (4) Gradually turn clockwise the current setting knob to the point where the C.V lamp (green) lights and the output power is delivered to the output terminals.

Setting of current limit

- (5) Keeping depressed the current/voltage limit switch, set the required constant current value with the current setting knob. Once this setting is done, no output current larger than the set value flows even when the load is rapidly changed. (The load is protected by automatically changing the instrument operation from the constant-voltage mode to the constant-current mode. This function is called "crossover".)

Notes: 1. Pay attention when setting the O.V.P. voltage.

At the instant the O.V.P. circuit operates, the input power switch is cut off. Set the O.V.P. voltage with an allowance of approximately 10%.

2. *When the load resistance is unpredictable or it is predicted to vary largely or when it has a large inductance and rapid voltage application is undesirable, gradually increase the output current by turning the current setting knob from the counterclockwise position in the clockwise direction.*

2-4. Constant-current Operation

- (1) Make sure that the AC line voltage is 200 V \pm 10% AC. Then, connect the input power.
- (2) Turn on the input power switch. The C.V or C.C lamp will turn on indicating that the power supply is in the operating state.
- (3) Keeping depressed the current/voltage limit switch, set the current at the required value with the constant-current knob and, at the same time, set the voltage limit value with the constant-voltage knob. Once this setting is done, the load is protected against overvoltage.
- (4) Turn off the input power switch. Connect the load to the output terminals of the power supply and, then, turn on the input power switch.

Notes: 1. If the load has a large inductance and it is undesirable to apply rapidly a large current, set the current setting knob in the extremely counterclockwise position and, then, turn on the power switch and gradually increase the current.

2. If the current/voltage limit switch is depressed when in the constant-current mode, the output current is reduced by approximately 2 mA from the preset value. Pay attention if the load is of such nature that this 2 mA change is critical.

SECTION 3. PROTECTORS

3-1. Description

Regulated DC power supplies are used, as their name indicates, to supply regulated powers to loads of various types of electronic equipment. Demands for regulated DC power supplies have rapidly increased in recent years. As is the case for other types of electronic equipment, these instruments are required to include features of fast response, high reliability, high efficiency, high power factor, compactness, light weight, and economical price.

Various types of power supplies are available on the market today.

When selecting regulated DC power supplies, in addition to satisfying the required performances, special attention must be paid to some particular requirements which are slightly different from those required by other types of electronic equipment which handle electronic signals.

The above difference comes from the fact that regulated DC power supplies handle "powers." Malfunctioning or erroneous operation of the power supply leads to shut down of the overall system, damage to the power supply equipment and expensive load equipment, or to a fire in an extreme case. As the power supply provides the base for the entire electric and electronic circuits of the system to which it supplies the power, its reliability is very important. Protective features, which prevent serious damage when the power supply should fail, are important factors to be taken into consideration when selecting a power supply.

The PAD-L Regulated Power Supplies have been designed fully taking the above matters into consideration, as instruments of very high reliability. They employ premium quality components, with sufficient derating. They are incorporated with protector which lead them to "the safer side" should they fail. Individual protectors are explained in this section.

3-2. Explanation of Protective Circuits

(1) Missing phase detection circuit:

This circuit detects the missing phase of the 3-phase AC input power. The missing phase is indicated by the POWER lamps on the front panel as the corresponding one of the lamps does not illuminate.

(2) Overvoltage protector:

When the output voltage has exceeded the preset voltage due to erroneous operation or an external pulse voltage, a thyristor circuit connected between the output terminals instantaneously conducts to short-circuit the output and, at the same time, the input power switch is instantaneously cut off.

(Triggered pulse width 200 μ sec)

(3) Voltage detection circuit:

When the rated voltage of the electrolytic filter capacitor is exceeded due to such erroneous operation as disconnected jumper of the terminal block on the rear panel or due to a failure of the rectifier circuit, the input power switch is instantaneously cut off.

(4) Overcurrent Protector:

The output current is limited at approximately 120% of the rated current.

(5) Temperature detection circuit:

Detects temperature of the cooling package (semiconductor cooling unit). When temperature of the cooling fins has become higher than approximately 100°C (212°F) due to ambient temperature rise or cooling fan failure, the input power switch is cut off.

The circuit also detects temperature of the power resistor terminal and that of the main transformer core and, when the detected temperature has exceeded a certain limit, turns off the input power switch.

(6) Rush current suppression circuit:

To suppress the current which could flow when the power switch is turned on to a value not greater than 300 A (peak).

(7) Power fuse:

Limits the input current.

(8) Output fuse:

Limits the output current.

Both fuses are current limiting type of fuses meeting the requirements of JIS and model-approved by the Electrical Appliance Control Ordinance. The fuses employ a ceramic insulation tube and silica sand arc killer, and are free of flame when blown out.

(9) Overcurrent detection circuit

When the input current has exceeded the rated limit, the power switch is turned off.

3-3. Operation Method of Overvoltage Protector (OVP)

When the load is a semiconductor or other device which is not resistant against overvoltage, set the OVP thyristor switch (CROWBAR mode select switch) to the ON state. For other types of loads, set the switch to the OFF state.

OVP Setting Procedure

- (1) As you press the OVP PRESET button, the voltmeter indicates the OVP trip voltage.
- (2) Keeping the button depressed, set the voltage using a plain screwdriver.
- (3) Check that the OVP circuit trips by raising the output voltage. (It may be necessary to wait approximately 60 seconds before turning on the input switch again.)
 - o If the OVP PRESET button and CURRENT/VOLTAGE LIMIT switch button are depressed at the same time, the OVP PRESET button has a priority.
 - o Even when the power supply is in use, voltage setting can be confirmed without affecting to the load and without interrupting the protective function.

Note: Be sure to set the OVP thyristor switch to the OFF state when the load is a battery or a large capacitor or when two or more power supplies are operated in parallel, the thyristor may be burnt when the OVP has tripped. (See Section 2-1.)

SECTION 4. APPLICATIONS

4-1. Remote Sensing

Voltage drop caused by the load connection wire resistance and contact resistance can be compensated for.

1. Turn off the input power switch .
2. Disconnect the jumper wires from between \oplus and \oplus terminals and between \ominus and \ominus terminals on the instrument rear panel.
3. Connect the \oplus and \ominus wires to the point where the output voltage drop is required to be compensated for. (Use a shielded cable in order to prevent induction of ripple voltage. Connect the external shielding wire to the \oplus line of the output.)

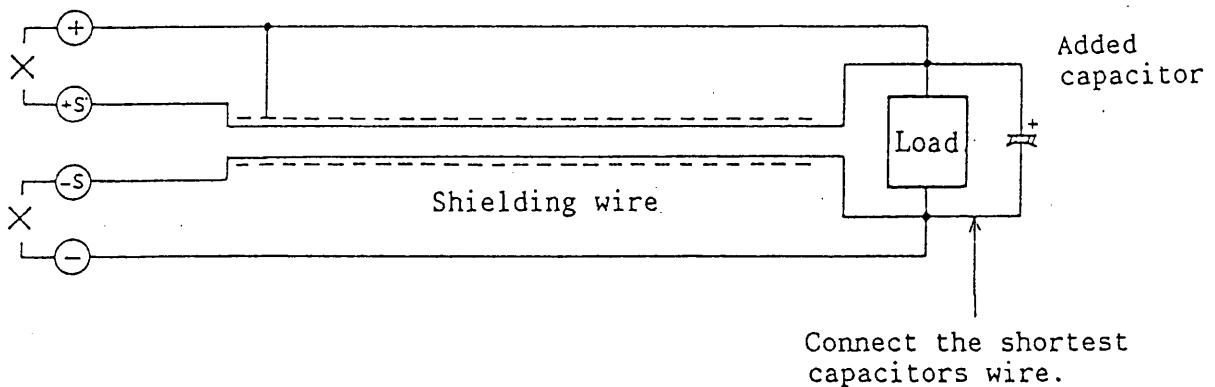

Figure 4-1

Notes: 1. By this remote sensing feature, up to approximately 1.2 V of voltage drop per one-way of connection wire can be compensated for. Note that, if the voltage drop is larger than 0.3 V, the maximum rated voltage is reduced by the corresponding amount.

2. If the load connection cable is longer than 3 - 5 meters, phase shift caused by inductance and capacitance of the cable wires becomes noticeable and the circuit may oscillate. In such a case, connect an electrolytic capacitor of several hundred microfarads in parallel with the load as shown in Figure 4-1.

4-2. Output Voltage Control with an External Voltage or Resistance

A. Control with an external resistance - I

1. Turn off the input power switch. (Be sure to turn off the input power switch whenever connecting or disconnecting wires of the rear terminals.)
2. Disconnect the jumper from between terminal ③ and ④.
3. Connect a 100-ohm potentiometer and another potentiometer (R1) between terminals ④ and ⑤.
4. Set R1 at zero and so adjust the 100-ohm potentiometer that the output voltage becomes zero.

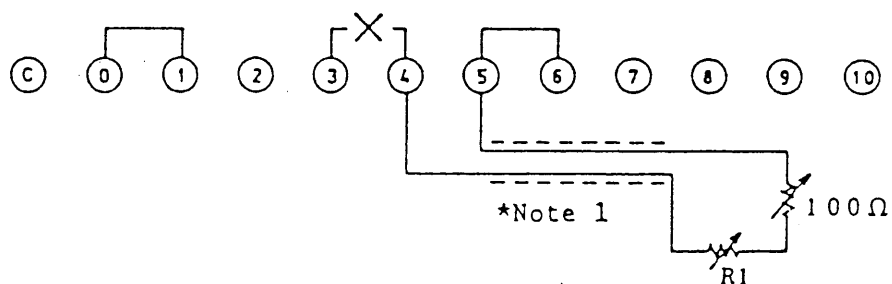

Figure 4-2

$$\text{Output voltage } E_o \cong \frac{E_{\text{max}} \cdot R_1}{10} \text{ [V]}$$

Where, $10 \geq R_1$ [k Ω]

E_{max} : Rated output voltage [V]

A current of 1 mA flows between terminals ④ and ⑤.

**Note 1: Use a 2-core shielded cable or a pair of stranded wires. Connect the shield wire to the "+" output terminal. Use the resistor R1 of good temperature characteristics, low noise and less aging degradation.*

**Note 2: Note that, if the circuit between terminals ④ and ⑤ is made open, the output voltage becomes uncontrollable and may rise sharply. Make sure that the circuit is securely closed.*

o Application

- o By using a fixed resistor and a potentiometer, the voltage can be varied by plus or minus several percent of the set voltage.
- o Resolution of the output voltage depends on resistor R1. Therefore, required resolution can be obtained by using an appropriate value of potentiometer for R1.
- o A programmed voltage can be obtained by varying the resistance with switch setting. (For this purpose, use switches of a closed circuit type or continuous type which do not cause momentary open circuit.)

B. Control with an external resistance - II

(This method is a fail-safe method free from overshoots even when resistors are switched.)

1. Turn off the input power switch.

2. Disconnect the jumper from between terminals ⑤ and ⑥.
3. Connect the resistor (potentiometer R2) between terminals ⑤ and ⑥.

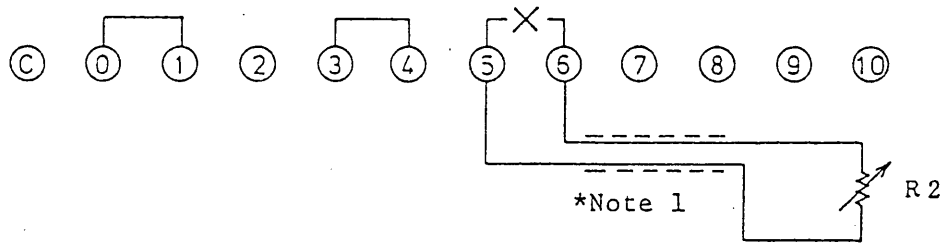

Figure 4-3

$$E_o \cong \frac{b}{a + R_2} \times E_{ref} \text{ [V]}$$

E_o : Output voltage

E_{ref} : Reference voltage, 0 to 10 V

R_2 : $0 \leq R_2 \leq \infty$ (infinite)

a, b : Constants (depend on model)

Model PAD-		35-300LPT	60-200LPT		
a	[k Ω]	3.4	5.2		
b	[k Ω]	12	31.6		

Table 4-1

The output voltage (E_o) is inversely proportional to the resistance (R_2) as shown below. Therefore, when the circuit has become open due to switching of resistors or a failure, the resistance becomes infinity and the output is reduced to zero.

**Note 1: Use a 2-core shielded cable or a pair of stranded wires. Connect the shield wire to the "+" output terminal. Use the resistor R2 of good temperature characteristics, low noise and less aging degradation.*

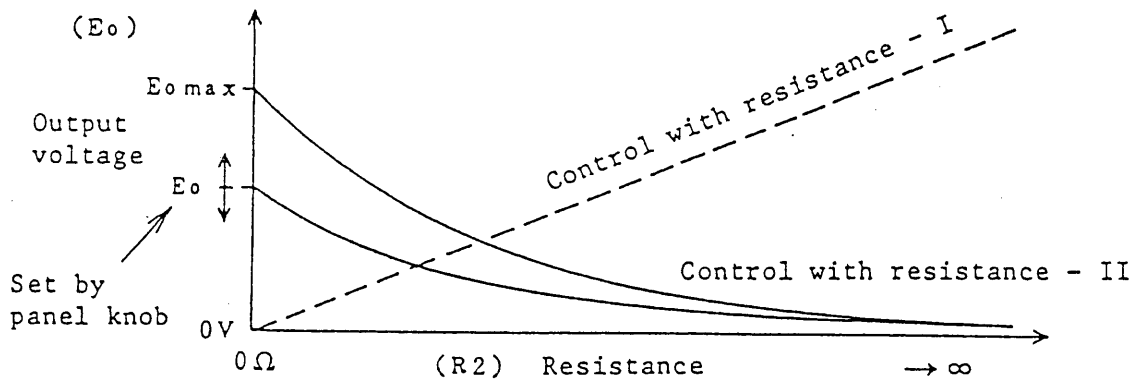

Figure 4-4

- Output voltage E_o can be calculated from R_2 and E_{ref} , using the above equation. E_{ref} can be set by means of the voltage setting knob on the front panel. (When the knob on the front panel is to be made ineffective. Use a "guard cap" (accessory, see page 15.).)
- The primary objective of this mode of operation is to attain such a fail-safe feature that the output voltage drops when the output circuit is inadvertently made open. A disadvantage of this mode of operation is that a high resistor is required when programming for operation at low voltages. In general, a potentiometer of 0 - 200 k Ω or thereabout is used. (When using a high resistor, pay attention its temperature coefficient and noise property.)

C. Control with an external voltage

1. Turn off the input power switch.
2. Disconnect the jumper from between terminals ⑤ and ⑥.
3. Apply an external control voltage between terminals ⑥ and ⑤.

(Pay attention to the polarity.)
 The terminal for the common line of the control voltage signal is +S. The external control voltage signal must be of an isolated type. Note that the power supply may be damaged if the control voltage signal is not of an isolated type. When the output is controlled for both constant-current and constant-voltage simultaneously, the respective control voltage signals must be of an isolated type because the common lines of the two control circuits are not connected in common.

- * The instrument may be damaged if there is a wrong connection or an abnormally large voltage is applied. Check for them once more before turning on the instrument power.

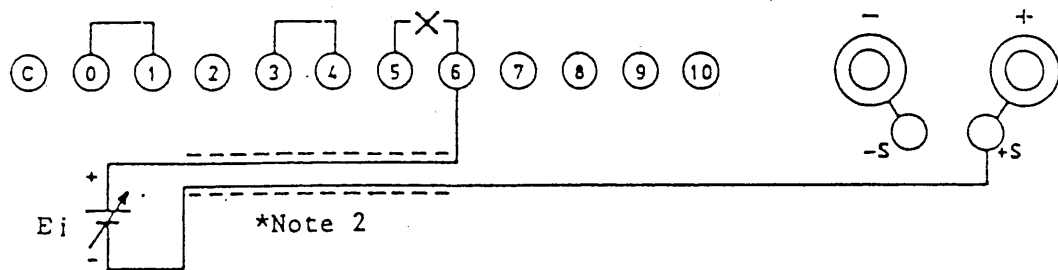

Figure 4-5

$$\text{Output voltage } E_o \approx \frac{E_{\text{max}} \cdot E_i}{10} \text{ [V]}$$

Where, $0 \leq E_i \leq 11\text{V}$

E_o : Output voltage [V]

E_i : Input control voltage [V]

E_{max} : Maximum rated voltage [V]

- Notes:
1. Make sure that the output voltage does not exceed the maximum rated voltage.
 2. Before this operation, set the OVP circuit in order to guard against overvoltage.
 3. Keep the input control voltage within a range of 0V to 11V.
 4. The input resistance between terminals ⑥ and ⑤ is 3 to 10 k Ω .
 5. Noise included in the input control voltage is amplified and reflected on the output voltage. Sufficiently reduce the noise component of the input control voltage.

*Note 2: Use a 2-core shielded cable or a pair of stranded wires. Connect the shield wire to the "+" output terminal.

o Input offset voltage

The input/output relationship of this instrument is with an input offset voltage as illustrated in the left. With this offset, zero-volt output is guaranteed even when there is residual resistance of the potentiometer or wiring resistance of external resistance control.

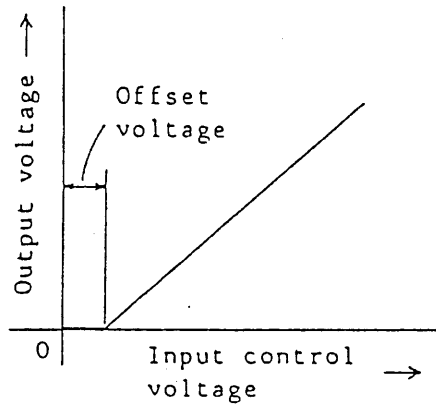

Figure 4-6

The input offset voltage can be adjusted with the output voltage offset control.

4-3. On-off Control of Output

A. For voltage preset with voltage limit switch when output is off

1. Turn off the input power switch.
2. Connect an external switch between terminals ① and ②.
3. Turn on the input power switch. If the external switch is turned on, the output becomes almost zero. If it is turned off, the output power is delivered.

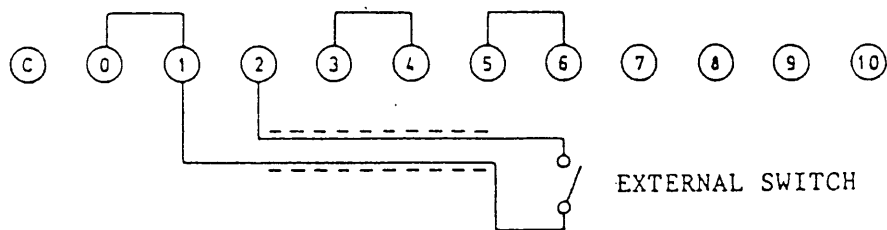

Figure 4-7

Note: When the output is in the off state, the output voltage of less than 0.6 V in the reverse polarity may be produced and a current of approximately 10 mA may flow depending on the type of the power supply. If such remaining voltage is not allowable, use method B explained in the subsequent paragraph.

When the output is off, the current limit switch cannot be used.

B. To make the output voltage accurately zero volts

1. Turn off the power switch.
2. Connect an external switch and a 100-ohm potentiometer between terminals ④ and ⑤.
3. Turn on the input power switch. Next, turn on the external switch.
4. Adjust the output voltage to zero volts with the potentiometer.
5. If the external switch is turned on, the output voltage becomes zero; if it is turned off, the output power is delivered.

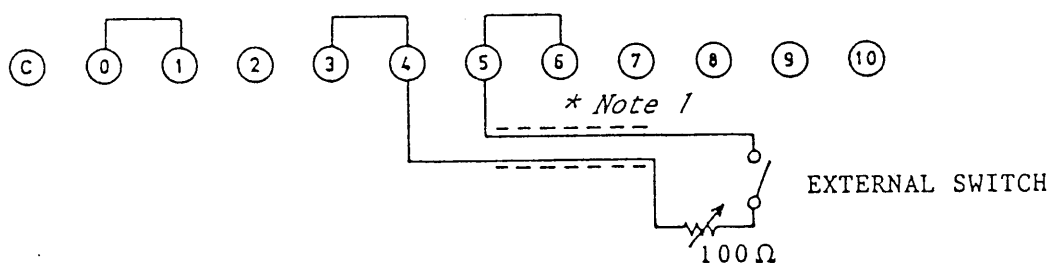

Figure 4-8

Note: When the output is off, the voltage limit switch cannot be used.

Note 1: Use a 2-core shielded cable or a pair of stranded wires. Connect the shield wire to the "+" output terminal.

4-4. Output Current Control with an External Voltage or Resistance

A. Control with an external resistance

1. Turn off the input power switch. (Be sure to turn off the power switch whenever connecting or disconnecting wires of the rear terminals.)
2. Disconnect the jumper from between terminals ① and ①.
3. Connect R2 and R3 potentiometers between terminals ① and ②.
4. Adjust the R3 potentiometer so that the output current becomes zero when R2 is zero.

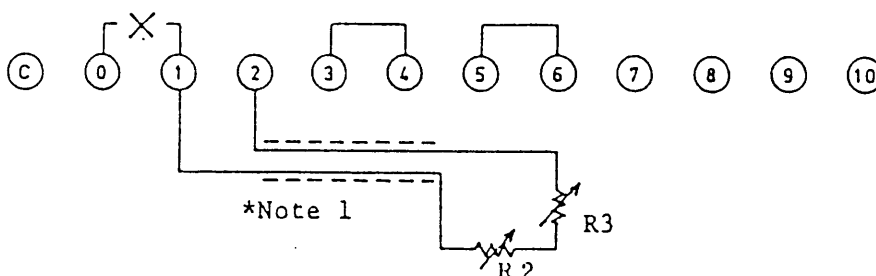

Figure 4-9

$$\text{Output current } I_o \cong \frac{R2 \cdot I_{\text{omax}}}{B} \text{ [A]}$$

**Note 2*

Where, $R2 \leq B$ [Ω] $R3$: Approx. 10 - 30 [Ω]
 I_{omax} : Rated output current [A]

Model PAD-		35-300LPT	60-200LPT		
B		500	500		

Table 4-2

**Note 1: Use a 2-core shielded cable or a pair of stranded wires. Connect the shield wire to the "+" output terminal.*

**Note 2: Linearity between R2 and I_o is approximately 5%. Use the external resistor R2 of good temperature characteristics, low noise and less aging degradation.*

B. Control with an external voltage

1. Turn off the power switch.
2. Disconnect the jumper from between terminals ① and ①.
3. Throw switch SW1 on PCB A-200A board to the upper position as shown in Figure 4-11. For location of the PCB, see Figure 6-1.
4. Connect electrolytic capacitor between terminals ① and ②.
5. Apply the external control voltage between terminals ① and ②. The potential of control common terminal ② is almost identical with that of output terminal ⊕. The external control voltage signal must be of an isolated type.

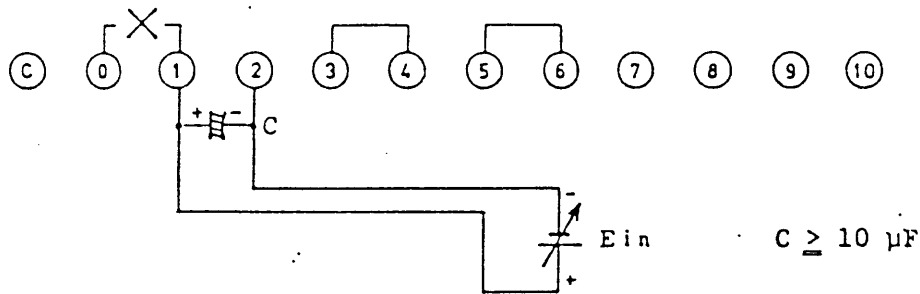

Figure 4-10

$$I_{out} \approx \frac{E_{in}}{R} \quad [A]$$

Where, $E_{in} [V] \leq E_{in \max}$

I_{out} : Output current

E_{in} : Input voltage

R : Detecting resistor

$E_{in \max}$: Maximum input voltage

Model PAD-		35-300LPT	60-200LPT		
R [Ω]		0.001	0.0015		
$E_{in \max} [V]$		0.33	0.33		

Table 4-3

- Notes:
1. Make sure that the output current does not exceed the maximum rated current.
 2. The input voltage (external control voltage) must be with in a range of 0 V to the maximum input voltage.
 3. Noise included in the input voltage is amplified and reflected on the output voltage. Sufficiently reduce the noise component of the input signal.
 4. Be sure to throw switch SW1 to the original state (lower position) after the operation in the remote control mode is over.

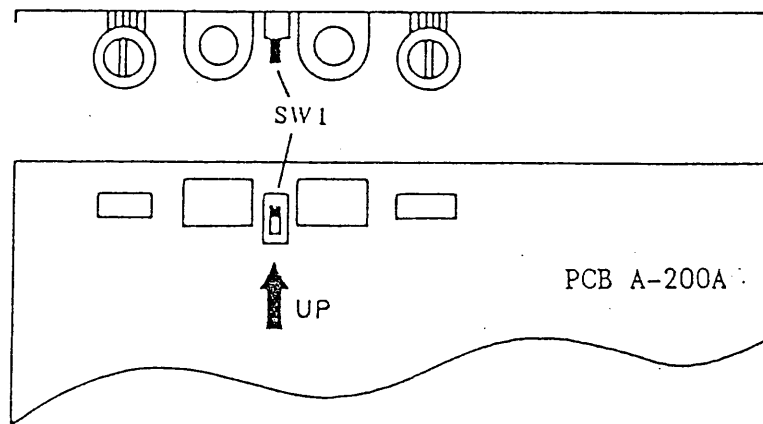
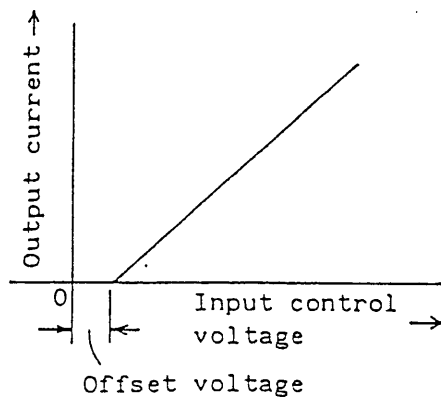

Figure 4-11

- o There is an offset voltage between the input control voltage and the output current as shown below.



For particular applications which do not tolerate this offset voltage, adjust it with the output current offset control.

Figure 4-12

4-5. One-control Parallel Operation

One master unit and any number of slave units can be operated in parallel to increase the current capacity, controlled by one unit (master unit) for operation.

4-5-1. Procedure When OVP Thyristor Switch is OFF

When the OVP thyristor switch is set to the OFF state, proceed as described below. (When it is set to the ON state, proceed as described in Section 4-5-2.)

1. Turn off the input power switch.
2. Disconnect the jumper from between terminals ⑩ and ① of each slave unit.
3. Connect terminal ③ of the master unit to terminals ① of all slave units.
4. Connect parallel the output terminals of all units, for each polarity.

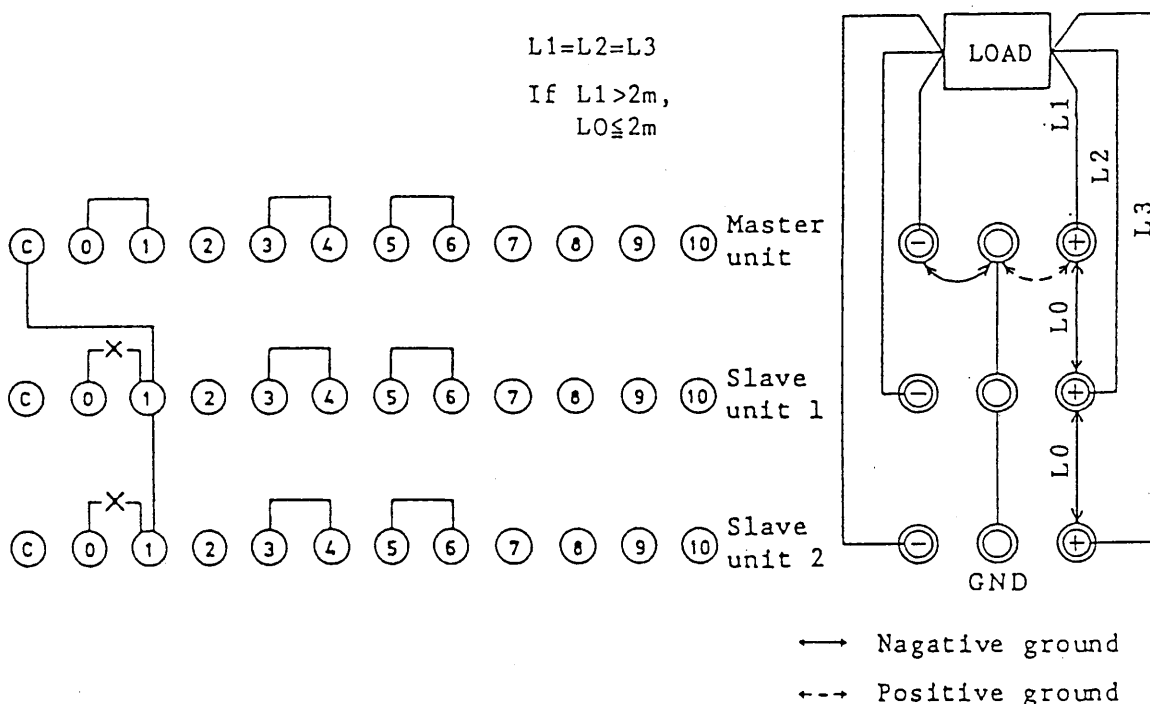

Set the constant-voltage setting knobs of all slave units to maximum position. Of the master unit, the green lamp lights to indicate the constant-voltage mode; of the slave units, the red lamps light to indicate the constant-current mode.

Figure 4-13

5. For one-control parallel operation, connect the GND terminals as shown in Figure 4-13.
6. For one control parallel operation with remote sensing, disconnect the jumper wires from between \oplus and \oplus terminals and \oplus and \ominus terminals of the master unit, and make required connections for the master unit as explained in 4-1 "remote sensing".

Note 1: Set the constant-voltage setting knobs of the slave units to the maximum position. For the wire gauges for the required currents, see Table 2-1.

Note 2: If the OVP trips when the OVP thyristor switch is set to the ON state, the entire current of the power supply units connected in parallel will flow through the thyristor and it will be burnt. Be sure to observe the method described in Section 4-5-2 when the OVP thyristor switch is set to the ON state.

4-5-2 Procedure When OVP Thyristor Switch is ON

1. When the OVP thyristor switch is set to the ON state, make connections as mentioned below in addition to those mentioned in Section 4-5-1.
2. Connect DIN connector pins ⑥ and ⑤ of the slave unit(s) to rear terminals ⑦ and ⑧ of the master unit. (See Figure 4-14.)

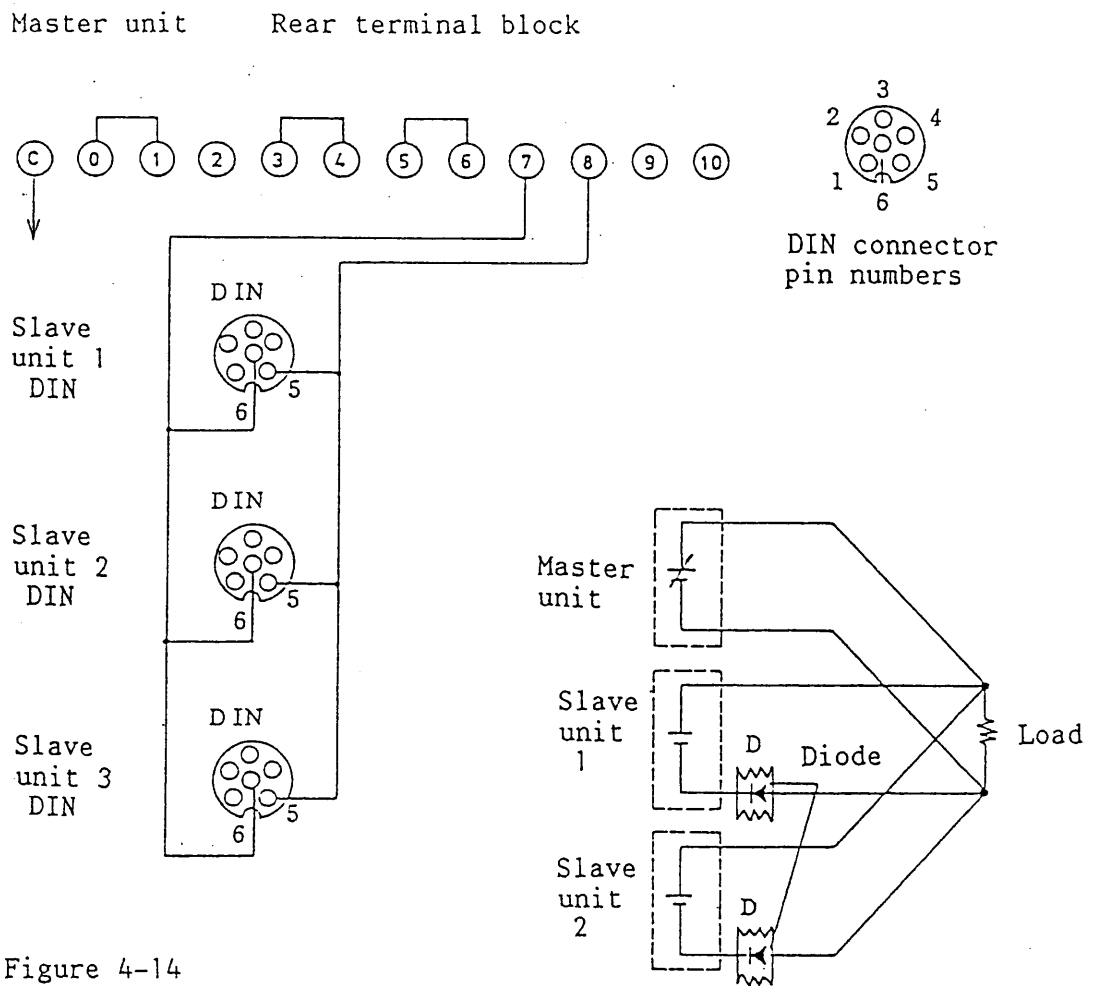

Figure 4-14

(Note 1)
When diode (D) is connected in the "-" output line of each slave unit, connections indicated in Figure 4-14 are not necessary.

Figure 4-15

3. To turn on the power supply system, turn on power of the slave unit(s) first and that of the master unit last. (Unless power of the slave unit(s) has been turned on, that of the master unit cannot be turned on.)

o Overvoltage Protection

At the instant the thyristor connected in parallel to the output terminals has started conducting, the power switch of the master unit is turned off and the entire output falls. When the power supply system requires a redundancy feature, connect a diode (D) in series of the "-" output line of each slave unit as shown in Figure 4-15. In this case, the connections indicated in Figure 4-14 is not necessary. Although the redundancy is not for the master unit, even when one of the slave units has failed, the failure is confined within the failed unit alone (its OVP trips) and the entire system is not turned down.

Note: The diode (D) must have a sufficient power rating to draw the rated output current and must be provided with a heat sink.

4-6. One-control Series Operation

One master unit and any number of slave units can be operated in series to obtain a higher output voltage (up to 250 V), controlled by one unit (master unit) for operation.

1. Turn off the input power switch.
2. Disconnect the jumper from between terminals ⑤ and ⑥ of each slave unit.
3. Connect external resistors as shown in Figure 4-16.
4. Connect the output terminals of all units in series.
(Use the rear terminals.)
5. Connect the GND terminals of all units as shown in Figure 4-17.
6. Set the current setting knobs of all slave unit in the maximum position.

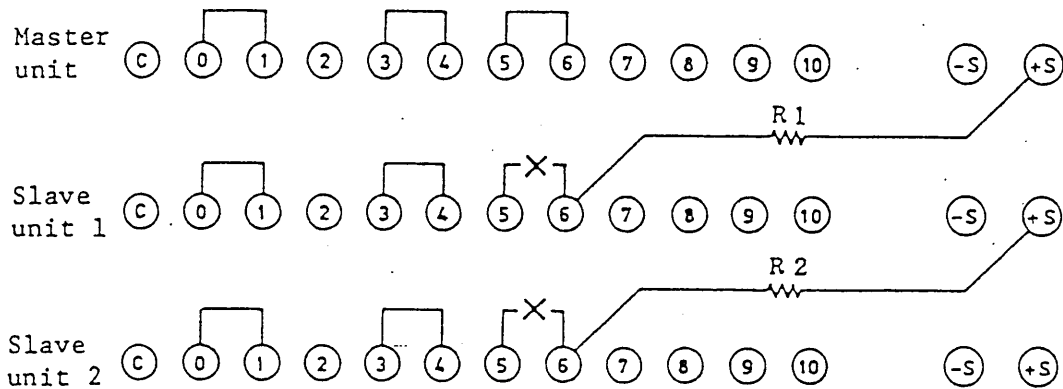

Figure 4-16. Rear terminal connections

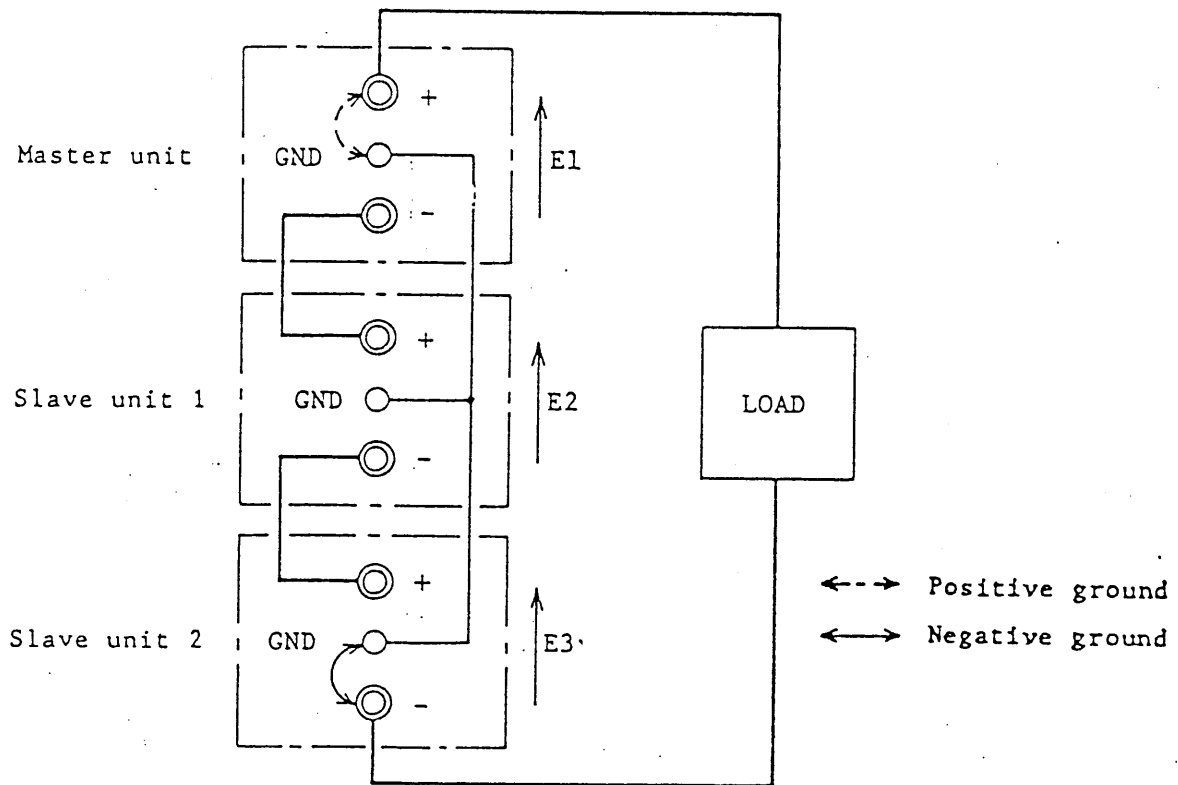

Figure 4-17. Output terminal connections

Resistance Calculation for External Resistor R1 (R2)

$$R1 = \left(\frac{E1}{E2} \times A \right) - B$$

where, $R1 \geq 0$ [k Ω]

E1 [V]: Master unit output voltage

E2 [V]: Output voltage of slave unit 1 when master unit output voltage is E1.

A, B: Constant of slave unit 1. (See Table 4-4.)

Resistance R2 can be calculated in a similar manner as above, using E2 for E1 and E3 for E2. In this case, slave unit 1 operates as the master unit and slave unit 2 operates as slave unit 1.

Model PAD-		35-300LPT	60-200LPT		
A [kΩ]		12	31.6		
B [kΩ]		3.4	5.2		

Table 4-4

Notes: o Make the maximum voltage when in series operation not greater than the allowable voltage of the instruments with respect to the ground.

o Set at the maximum the constant-current setting knob of the slave units.

o For external resistor R1 (R2), use one with a sufficient wattage allowance. Use a resistor of good temperature coefficient and aging characteristics.

o The actual value of R1 may be slightly different from the calculated value. In such a case, adjust the value of R1 (R2).

Applications:

1. For one-control series operation with remote sensing, disconnect the jumper wires from the "⊕ ↔ ⊖" terminals of the master unit and the "⊕ ↔ ⊖" terminals of slave unit 2 (the last unit), and connect the sensing wires to these terminals. (Refer to the sections for remote sensing.)
2. One-control series operation with other models of this series of instruments also can be done. In such case, the output current is limited by the model of the smallest current rating and, therefore, it is recommended to use as the master instrument the one the current rating of which is the smallest.

4-7. Constant-current Charge/Discharge of Battery or Capacitor

A. Charge (constant current)

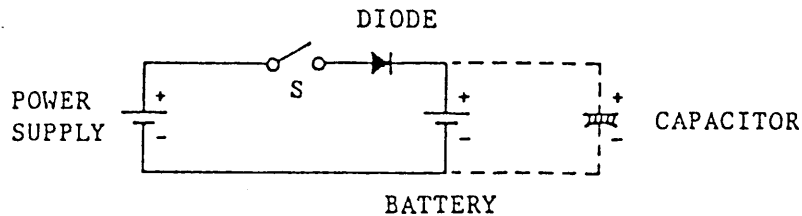

Figure 4-18

1. Keeping depressed the current/voltage limit switch, set the charge end voltage with the constant-voltage setting knob and the charge current with the constant-current setting knob.
2. Close switch S so that the charging operation starts. When the charge end voltage is reached, the charging operation stops automatically. (The power supply employs a potentiometer burn protection circuit.)

Notes: 1. Connect the battery in the same polarity with the power supply. (If it is connected in the reverse polarity, the power supply may be damaged.)

2. *If the output voltage of power supply is lower than the battery voltage or if the power switch is off, a current of several hundreds milliamperes flows from the battery into the power supply. If this current is not allowable, connect a diode in series with the battery as shown in Figure 4-18.*

B. Discharge (constant current)

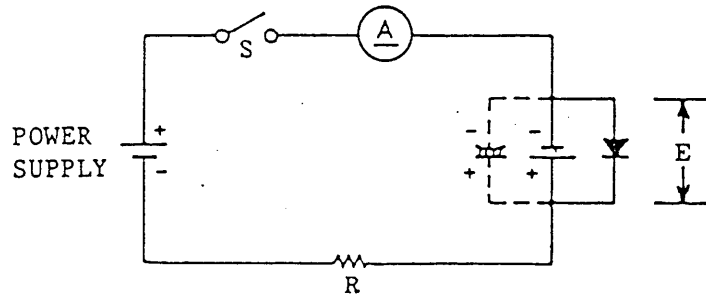

Figure 4-19

Resistance of R: $R = \frac{E \text{ [V]}}{I \text{ [A]}}$

Power consumption by R: $P = I^2R \text{ [W]}$

where, E: Terminal voltage of battery or capacitor when starting discharge

R: Discharge resistor

I: Discharge current (constant current)

D: Reverse current blocking diode

1. Set the output voltage of the power supply with the constant-voltage setting knob to a voltage higher by several volts than the terminal voltage of the battery or capacitor which is to be discharged. (Once this setting is done, constant-current discharge is done until the voltage of the battery or capacitor becomes zero.)
2. Calculate the resistance of the discharge load resistor (R). Pay attention to the wattage of the resistor.
3. Keeping depressed the current/voltage limit switch, set the discharge current with the constant-current setting knob.

4. Close switch S. Constant-current discharge operation will start.

Notes: 1. To stop discharge, open switch S. (Even when the input power switch of the power supply is cut off, the discharge current flows through the diode which is connected in parallel with the output circuit of the power supply.)

2. Be sure to connect the discharge load resistor (R). (If the battery or capacitor is directly connected, the power supply may be damaged.)

3. Be sure to connect the reverse current blocking diode.

4-8. Remote Turning Off of The Power Switch

To turn off the power switch, short-circuit between terminals ⑦ and ⑧ on the rear terminal board.

Note: As terminals ⑦ and ⑧ are at the potential of the "+" terminal of the filter capacitor, a floated (isolated) external contact signal is required for the remote control signal.

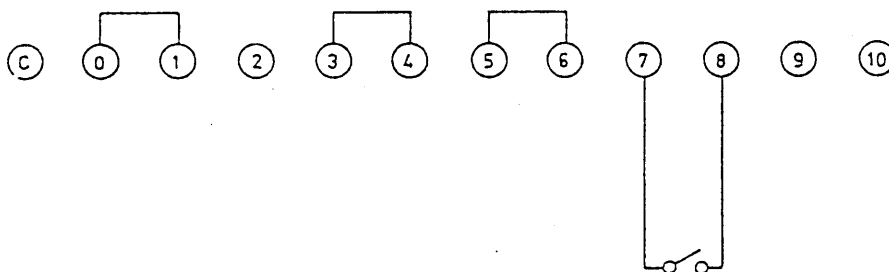

Figure 4-20

(Contact rating: 10 V,
100 mA DC or more)

4-9. Contact Signals

The contact signals representing the constant-voltage mode, and constant current mode are delivered to the DIN terminal on rear panel.

- Contact output for C.V/C.C operation indication: See the drawing below.
- Contact output for OVP operation (power ON/OFF) indication: See the chart below.
(POWER ON/OFF OPERATION indication)

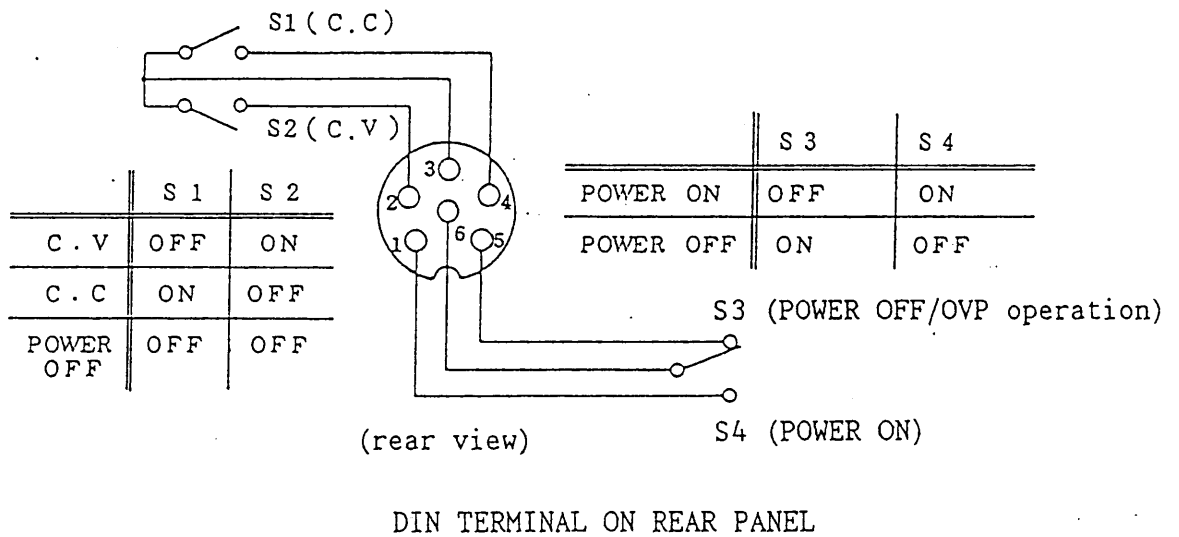

Figure 4-21

Isolation:

Between chassis and terminals 250 V DC

Contact rating:

24 V DC, 0.2A/100V AC, 0.05 A	C.V and C.C
24 V DC, 1A/100V AC, 0.4 A	ON/OFF

SECTION 5. THEORY OF OPERATION

5-1. Description of Pre-regulation Circuit

Before describing the operating principles of individual circuits of the power supply, history of variable regulated DC power supplies are very briefly introduced in the following.

Figure 5-1 shows a series control circuit. This circuit, as compared with other types of control circuits, has a higher control accuracy and provides an output of higher quality. The output voltage is variable for a wide range. Therefore, this circuit is widely used for variable DC power supplies. This circuit, however, has a disadvantage that, when the output power is supplied to a load at a low voltage, V_{CE} increases and consequently collector loss P_C ($P_C = V_{CE} \times I_C$) increases and, therefore, rectifier voltage V_C is required to be varied with respect to the output voltage.

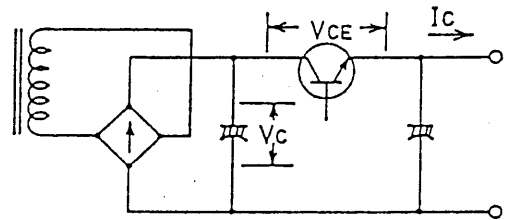

Figure 5-1
Series-controlled power supply

Figure 5-2 shows a power supply circuit which employs a relay system. Variation of the output voltage is detected and transformer taps are switched with a relay circuit to compensate for output variation. The PAC Series Power Supplies employs this system. This system provides excellent power supplies up to approximately 200 watts.

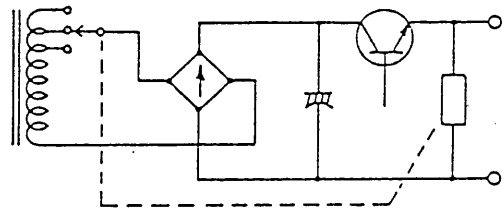

Figure 5-2
Variable regulated DC power supply circuit with relay switching.

For larger power supplies, however, this relay system has such disadvantages that mechanical contacts have limited life and require maintenance, a number of relays are required to reduce the collector loss, and consequently the reliability falls and the cost rises. To solve the problem, solid-state switching circuit has become most common.

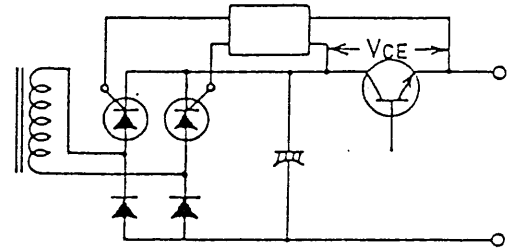

Figure 5-3
Variable regulated DC power supply with SCRs

Figure 5-3 shows the SCR system employed by the PAD Series Power Supplies. This system provides a fast response and V_{CE} can be maintained almost constant by phase control and, therefore, it enables high-accuracy large-rating variable power supplies. Thus, a large number of this type of power supplies have been manufactured by Kikusui. However, problems have arisen regarding increase of ripple current of the electrolytic capacitor as the filter circuit is a capacitor input type, the surge current of SCRs, and overheating due to copper loss of the transformer when the power factor has become poor.

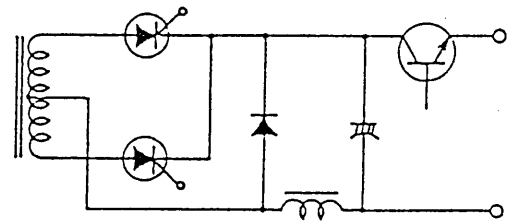

Figure 5-4
Principle of PAD-L Series Power Supplies

The PAD-L Series Power Supplies have solved the above problems by using a choke-input type filter circuit, and are the most reliable variable regulated DC power supplies available.

5-2. Controlled Rectifier Circuit and Filter Circuit

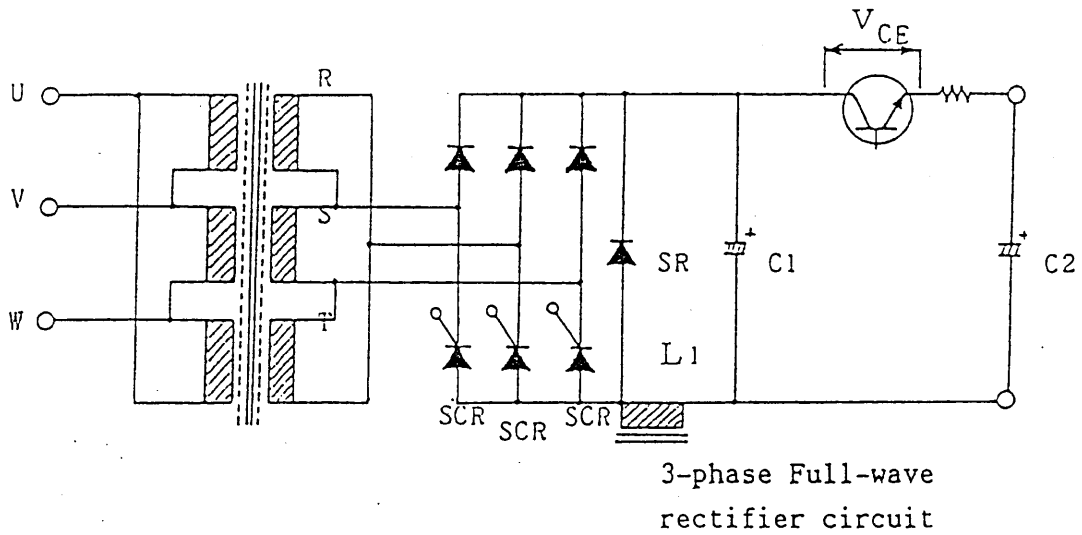

Figure 5-5

- This circuit rectifies the current with phase-controlled SCRs and the collector-emitter voltage of the series control transistor is maintained constant to reduce the collector loss.
- The filter circuit is a single-stage inverted-L choke input type.
- SR is a freewheeling diode, which is used as the load (filter circuit) of the rectifier circuit, is inductive in order to commutate the energy stored in the reactor and turn off the SCRs.
- This circuit, when the conducting angle of SCRs has become narrower, can prevent degradation of power factor (which is inherent to the phase-controlled circuit) more effectively as compared with the capacitor-input filter circuit. It also solves the problems of ripple current of electrolytic filter capacitor and overheating of the transformer, and reduces the rectified output ripples.

5-3. Phase Control Circuit

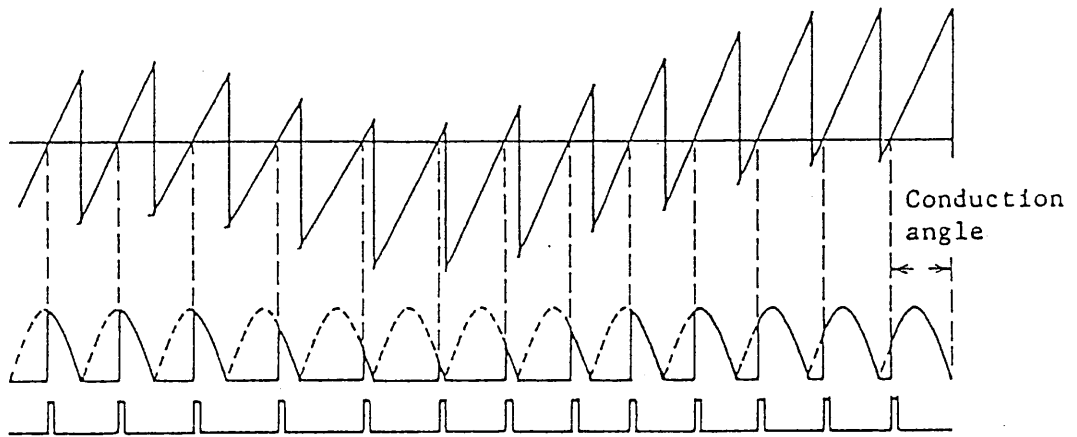

Figure 5-6

This circuit is a pulse phase modulator which operates in synchronization with the AC line frequency. When the collector-emitter voltage (V_{CE}) is large, the generated pulse signal is for a wider conduction angle and, when the voltage is lower, the signal is for a narrower conduction angle and, thus, the circuit so controls SCRs that V_{CE} becomes constant.

5-4. Constant-voltage Circuit

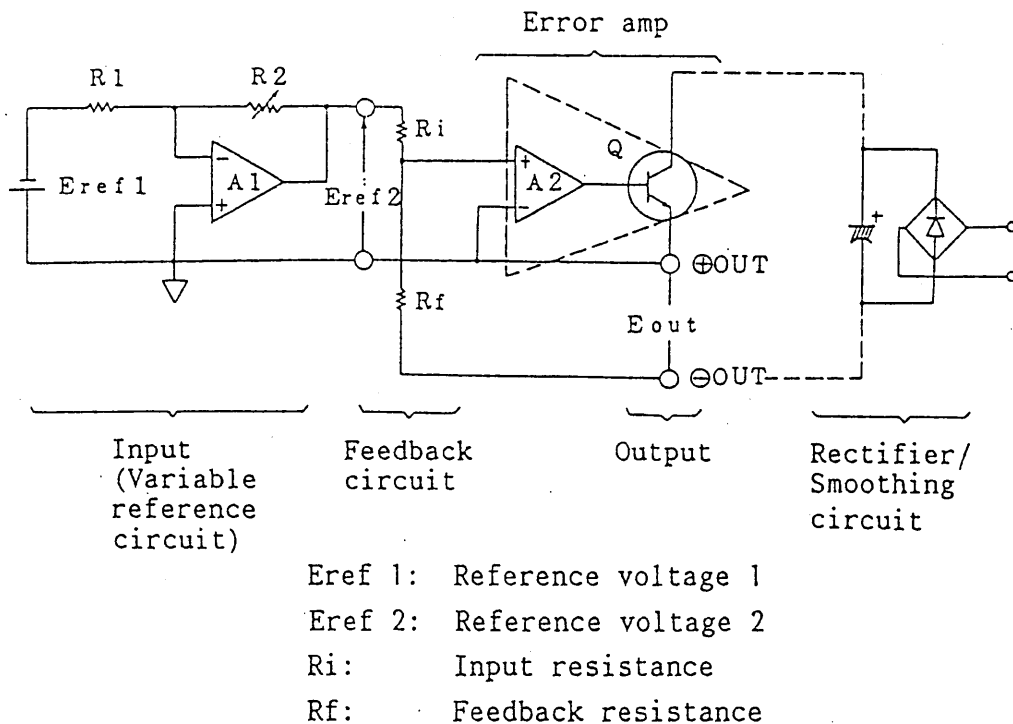

Figure 5-7

Output voltage E_{out} can be expressed as follows (A1 is an ideal amplifier):

$$E_{out} = - \frac{R_f}{R_i} E_{ref 2}$$

Thus, the output voltage depends only on $E_{ref 2}$, R_i and R_f .

The output voltage is linearly proportional to R_f and $E_{ref 2}$.

For this power supply, $E_{ref 2}$ is varied to control the output voltage.

$E_{ref 2}$ is produced by amplifying $E_{ref 1}$, and this voltage is linearly varied by R_2 .

To obtain a stable output voltage, such components as $E_{ref 1}$ diode, R_1 , R_2 , R_i , R_f , A1 and A2 must be sufficiently stable against change in external conditions. This power supply employs for the $E_{ref 1}$ diode a zener diode of excellent temperature characteristics. The resistors are metal-film resistors and wound-wire resistors of excellent temperature coefficient and aging characteristics. Amplifiers A1 and A2 employ monolithic ICs which ensure high gain, wide band and low drift.

The major factors caused by line voltage variation are variation of the operating point of the error amplifier and variation of the reference voltage due to dynamic resistance of the reference diode.

To guard against these variations, a stabilized internal auxiliary voltage source is used. Load variation ($\partial V_o/\partial I_o$: output variation caused by output current variation) is affected by output impedance (internal resistance) Z_o . (See Figure 5-8.)

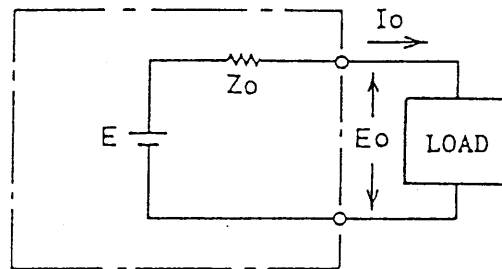

$$E_o = E - I_o Z_o$$

$$I_o Z_o = \text{Load variation component}$$

Figure 5-8

Denoting by A the open loop gain attained by error amplifier A_2 and power transistor Q , output impedance Z_o can be expressed as follows:

$$Z_o = \frac{R_o}{1 + AB}$$

$$\text{Where, } B = \frac{R_i}{R_f + R_i}$$

R_o : Output impedance of the circuit when no error amplifier is connected

The above equation indicates that the output impedance is improved to $1/(1 + AB)$ by connecting amplifier A_2 and effecting a feedback circuit.

5-5. Constant-current Circuit

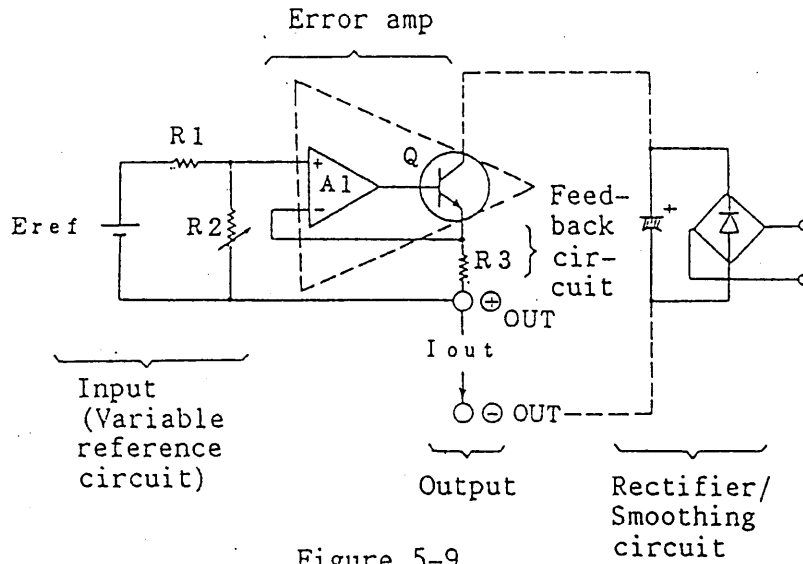

Figure 5-9

- Eref: Reference voltage for constant current
- R2: Output current control potentiometer
- R3: Output current detection resistor

Output current I_{out} can be expressed as follows (A1 assumes an ideal amplifier):

$$I_{out} = \frac{R2}{R3(R1 + R2)} \times E_{ref}$$

This equation indicates that the output current depends on E_{ref} , $R1$, $R2$ and $R3$. Of this power supply, the output current is controlled by varying $R2$. Note that the relationship between $R2$ and I_{out} is not linear as indicated with a solid line in Figure 5-10.

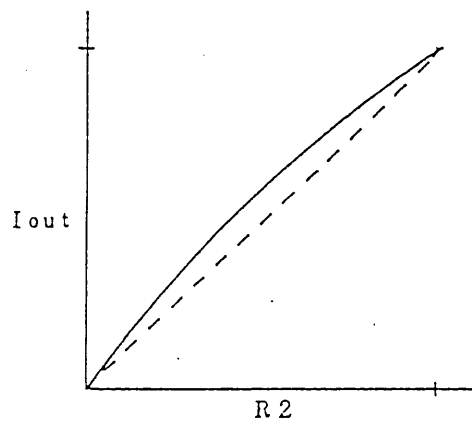
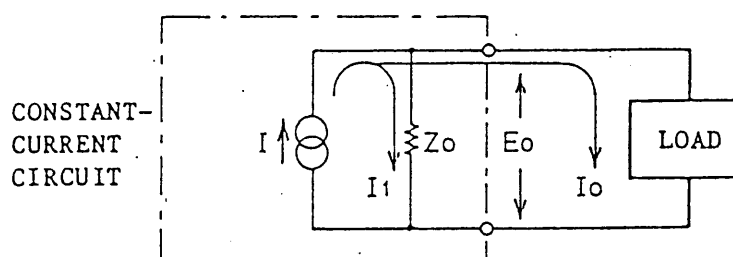

Figure 5-10

To ensure a stable output current, E_{ref} , R_1 , R_2 and R_3 must be sufficiently stable against change in external conditions (line voltage change, ambient temperature change, aging, and load change).

Error amplifier A1 must be a high-gain wide-band DC amplifier with less drift.

Of the constant-current circuit, the larger the output impedance (Z_{out}), the smaller is the load variation ($\partial I_o / \partial V_o$: output current variation caused by output voltage variation). (See Figure 5-11).



$$I_o = I - I_1$$

where, $I_1 = E_o / Z_o =$ Load current variation component

Figure 5-11

Denoting by g_m the mutual conductance attained by error amplifier A2 and power transistor Q, output impedance Z_o can be written as follows:

$$Z_o = (1 + g_m R_3) R_o$$

In this equation, R_o is the output impedance of the circuit before connecting the error amplifier. This equation indicates that the output impedance is improved by $(1 + g_m R_3)$ times by connecting amplifier A2 and providing negative feedback.

5-6A. Differences from Ideal Constant-voltage Supply

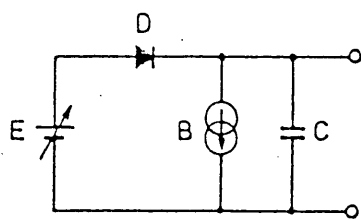

- E: Ideal constant-voltage supply
- D: Ideal diode
- B: Internal bleeder circuit
- C: Capacitor

Figure 5-12. Equivalent circuit of series-controlled constant-voltage DC power supply

o Cannot sink current:

Figure 5-12 shows an equivalent circuit of a series-controlled constant-voltage power supply of the type used for this and other power supplies. An ideal diode is connected in series. This type of power supply is for a load of such type that it simply drains the current and does not send back the current. For such load as a battery which sends back a current, however this power supply cannot sink such current.

This problem can be solved by using a parallel-controlled power supply or one which has a bi-polarity output. Such power supplies, however, will provide less efficiency and high cost for the same power.

The problem can be solved by connecting a resistor in parallel with the load and feeding in the resistor a current larger than the maximum reverse current. When the reverse current is small, the problem may be solved by connecting an electrolytic capacitor in parallel with the load. When the load is an inverter, a filter circuit may be provided in the input circuit to reduce the reverse current.

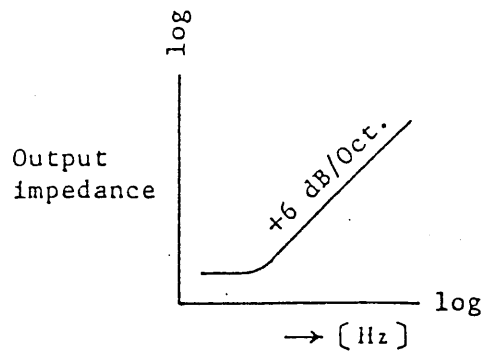

Figure 5-13
Frequency vs output
impedance characteristics

- o Output impedance is not infinity, with certain frequency characteristics:

Figure 5-13 shows that the output impedance (internal resistance) of this power supply increases as the frequency increases. This is because the gain of the loop including the error amplifier decreases. Better frequency characteristics, as well as DC output impedance characteristics such as for load variation, are a desirable feature for the power supply.

This feature must be such that not only the high gain region of the error amplifier is extended to a higher frequency range but also the phase characteristics are correct.

A shorter transient response time means better frequency characteristics of output impedance. Transient response time is an index for evaluation at the time range and output impedance is that at the frequency range.

5-6B. Difference from Ideal Constant-current Power Supply

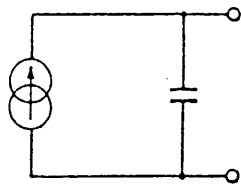
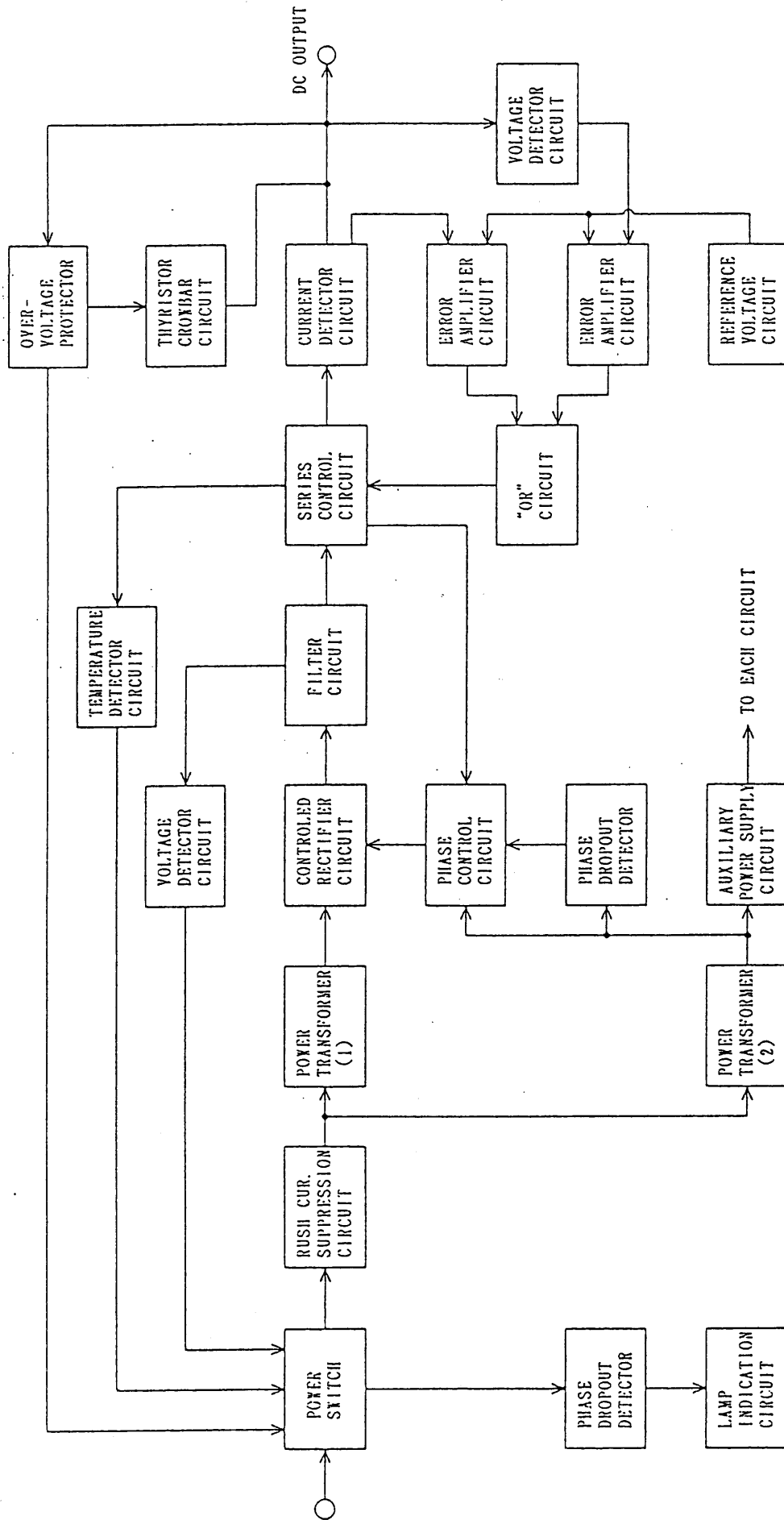

Figure 5-14

Figure 5-14 shows an equivalent circuit of this power supply operating as a constant-current source. A capacitor is connected in parallel with an ideal power supply.

There is no problem when the load is resistive. However, if the load is of such nature that it varies rapidly, pay attention to the fact that the output voltage also varies rapidly and the charge/discharge current of the capacitor is superimposed on the output current.



Block Diagram

SECTION 6. MAINTENANCE

6-1. Inspection and Adjustment

Periodically inspect and adjust the power supply so that it maintains its initial performance for a long time.

6-1-1. Removing Dust and Dirt

6-1-2. Inspecting the Power Cord and Plug

6-1-3. Calibrating the Voltmeter

6-1-4. Calibrating the Ammeter

6-1-5. Calibrating the Current/Voltage Limit Switch

6-1-6. Adjusting the Maximum Variable Constant-voltage Range

6-1-7. Adjusting the Maximum Variable Constant-current Range

6-1-1. Removing Dust and Dirt

When the instrument panel has become dirty, lightly wipe it with a cloth moistened with diluted neutral soapsuds or alcohol and, then, wipe it with a dry cloth. Do not use benzine or thinner. Blow away dust collected inside the instrument and in the ventilation holes of the casing, using a compressed air or a vacuum cleaner.

6-1-2. Inspecting the Power Cord and Plug

Check for that the vinyl cover of the cord is not damaged.
Check the plug for play, loose screws and damage.

6-1-3. Calibrating the Voltmeter

Connect an external voltmeter of an accuracy of 0.5% or better to the output terminals, set the output voltage at the value indicated on Table 6-1, and calibrate the instrument voltmeter with the potentiometer on the front panel. (See Figure 6-1.)

6-1-4. Calibrating the Ammeter

Connect an external ammeter of an accuracy of 0.5% or better in the output circuit, set the output current at the value indicated on Table 6-1, and calibrate the instrument ammeter with the potentiometer on the front panel. (See Figure 6-1.)

6-1-5. Calibrating the Current/Voltage Limit Switch

o Calibration of limit current

Set the output current at the value indicated on Table 6-1.

Press the current/voltage limit switch and so adjust R253 that the ammeter indicates the set current value.

o Calibration of limit voltage

Set the output voltage at the value indicated on Table 6-1.

Press the current/voltage limit switch and so adjust R209 that the voltmeter reads the set voltage value. (See Table 6-1.)

6-1-6. Adjustment of Maximum Variable Constant-voltage Range

Connect to the output terminals an external voltmeter of an accuracy of 0.5% or better, set the constant-voltage setting knob in the maximum position (extremely clockwise position), and so adjust R220 on PCB A-200A that the instrument voltmeter reads the value indicated on Table 6-1.

6-1-7. Adjustment of Maximum Variable Constant-current Range

Connect in the output circuit an external ammeter of an accuracy of 0.5% or better, set the constant-current setting knob in the maximum position (extremely clockwise position), and so adjust R249 on PCB A-200A that the instrument a ammeter reads the value indicated on Table 6-1. (See Figure 6-1.)

Model PAD-		35-200LPT	60-200LPT		
Voltmeter ADJ	R101	35 V	60 V		
Ammeter ADJ	R102	300 A	200 A		
Currnet limit ADJ	R253	300 A	200 A		
Voltage limit ADJ	R209	35 V	60 V		
Maximum voltage ADJ	R220	36 V	61 V		
Maximum current ADJ	R249	305 A	205 A		

Table 6-1

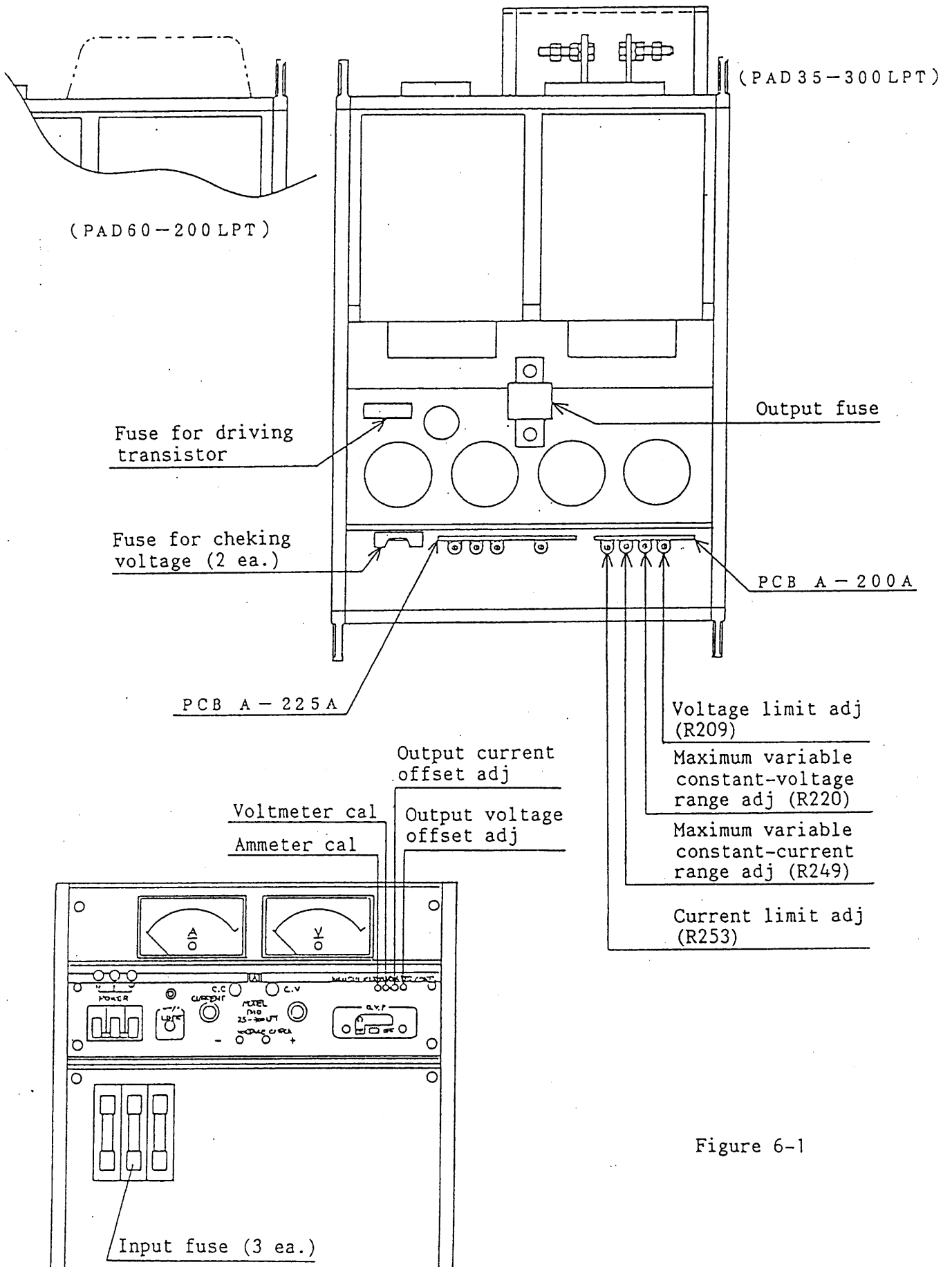

Figure 6-1

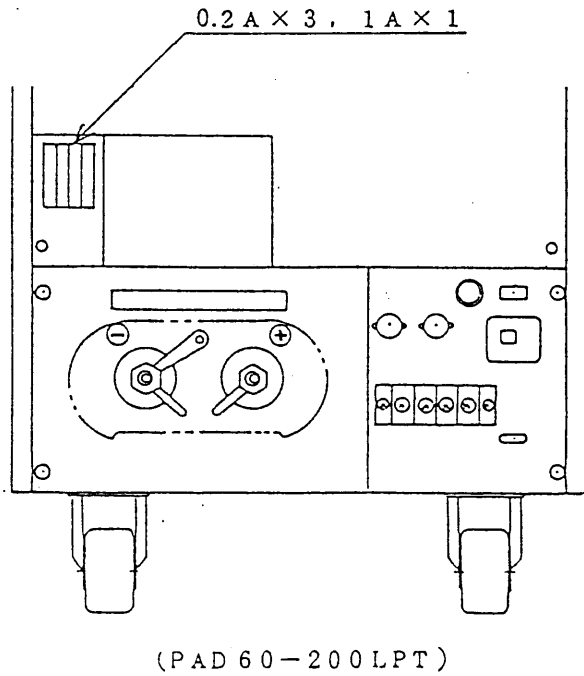
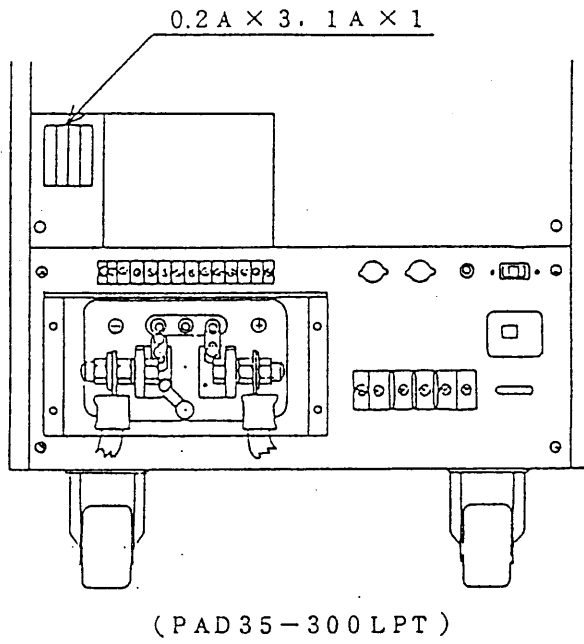

Figure 6-2

6-2. Troubleshooting

The most probable causes of troubles are shown in the following table. When a failure of the power supply is found, contact Kikusui agent in your area.

Symptom	Check item	Probable cause
Power switch cannot be turned off (or turns off soon). ALARM lamp is lighted.	1. Has the overvoltage protector tripped?	○ Set voltage too low
	2. Shorting bar disconnected?	○ Disconnected or loose shorting-bar
	3. Is fan stalled?	○ Trip of overheat protector (Replace fan.)
	4. Is the frequency select switch correctly	○ Incorrect setting of frequency select switch
	5. Other than the above	○ Trip of protector due to a failure of rectifier circuit
No output (No output is produced at all or only a slight output is produced.)	Is lamp lighted? If not lighted.	○ Trip of missing phase detection circuit
	1. Is the input power fuse blown?	○ Input of voltage too high (Replace fuse.)
	2. Missing phase? Open circuiting of input power cable	NOTE: Check the small fuses (0.2 amperes, three) also.
	3. Are the lamps alternately lighting, indicating rapid transitions of operating domains	○ Too narrow constant-voltage and constant-current setting ranges
	4. Are the shorting-bars correctly connected?	○ Wrong connection of shorting-bar(s)

Symptom	Check item	Probable cause
No output (No output is produced at all or only a slight output is produced.) (cont'd)	5. Is the output power fuse blown out?	<ul style="list-style-type: none"> ○ Output current flowed exceeding the rated value ○ Power transistor failure
	6. Is the circuit oscillating?	<ul style="list-style-type: none"> ○ Phase inversion caused by remote sensing circuit (Connect an electrolytic capacitor at the load end.) Refer to 4.1. ○ (Re-adjust)
	7. Is a current flowing despite no load?	<p>If flowing,</p> <ul style="list-style-type: none"> ○ Failure of the protective diode connected in parallel with the output (This diode may be damaged if such load as battery is connected in the reverse polarity.)
	8. Other than the above	<ul style="list-style-type: none"> ○ Circuit failure
Abnormally high output	1. Is the shorting-bar disconnected? (Between 3 and 4.)	<ul style="list-style-type: none"> ○ Disconnected or loose shorting-bar ○ Malfunctioning OVP circuit
	2. Output voltage (current) cannot be reduced	<ul style="list-style-type: none"> ○ Power transistor failure ○ Bleeder circuit failure

Symptom	Check item	Probable cause
Unstable output	1. Is the shorting-bar(s) loose?	○ Incorrect connection of the shorting-bar(s)
	2. In the remote control mode?	○ Noise introduced through leadwires
	3. Is the AC line voltage correct?	○ AC line voltage not within the specified range
	4. Special type of load	○ See 2-1. 7. (on page 14)
	5. In the remote sensing mode?	○ No electrolytic capacitor connected at load end
	6. When matter of drift is critical	○ Allow approximately 30 minutes of stabilization time.
	7. Other than the above	○ Circuit failure
Large ripple voltage	1. Is the AC line voltage correct?	○ Input voltage too low
	2. Are the sensing terminals securely connected to the output terminals?	○ Securely connect the sensing terminals
	3. Is a strong source of magnetic or electric field present near the power supply? (Is there no nearby auto-transformer, power transformer, or an oscillating source?) (Especially when in the constant-current mode)	○ Electromagnetic induction (Move the source of trouble. Strand the wires.)
	4. Other than the above	○ Circuit failure ○ (Re-adjust)

KIKUSUI ELECTRONICS CORP.

1-1-3, Higashiyamata, Tsuzuki-ku, Yokohama, 224-0023, Japan
Tel : 045-593-7570 Fax : 045-593-7571